



# HEIDENHAIN

**araxe**

72, rue Yves le Coz  
78000 VERSAILLES

tél : 01 30 21 48 49

fax : 01 39 51 16 33

<http://www.araxe.com>

[contact@araxe.com](mailto:contact@araxe.com)

**HEIDENHAIN**

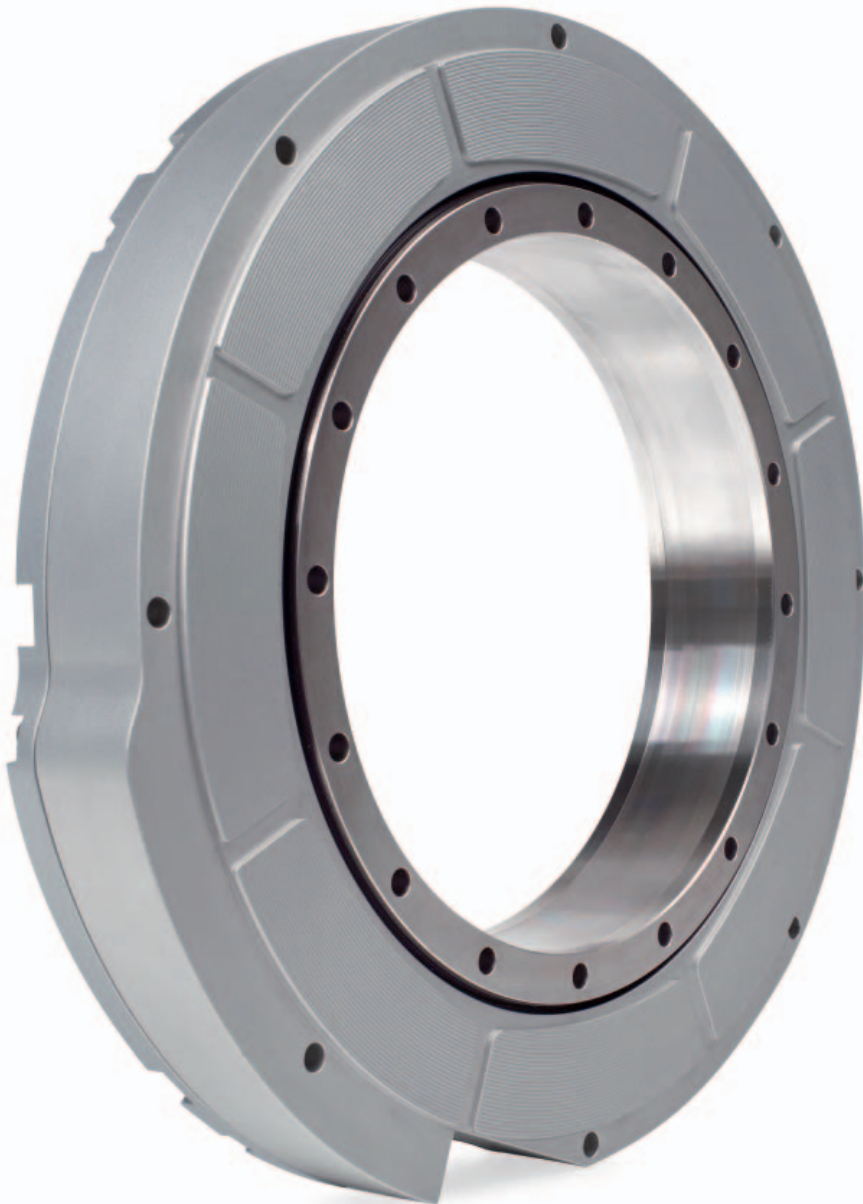

Product Information

## **RCN 6000**

Absolute Angle Encoder  
with Integral Bearing and  
Large Hollow Shaft

# RCN 6000 series

## Absolute angle encoder with

- Integrated stator coupling
- Hollow through shaft  $\varnothing 180$  mm
- System accuracy  $\pm 2''$

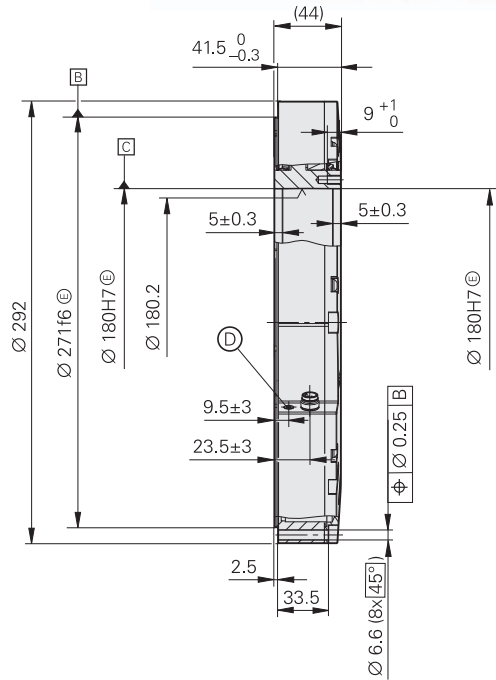
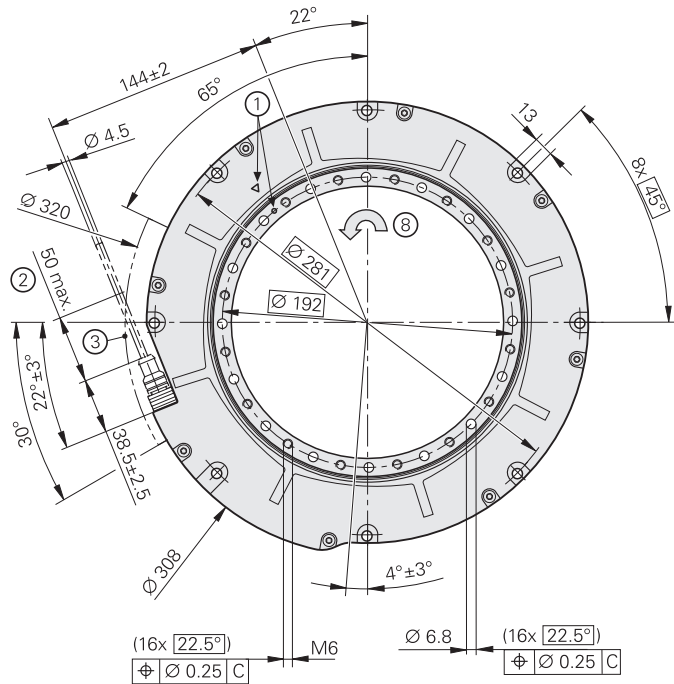

## Shaft coupling via through hole

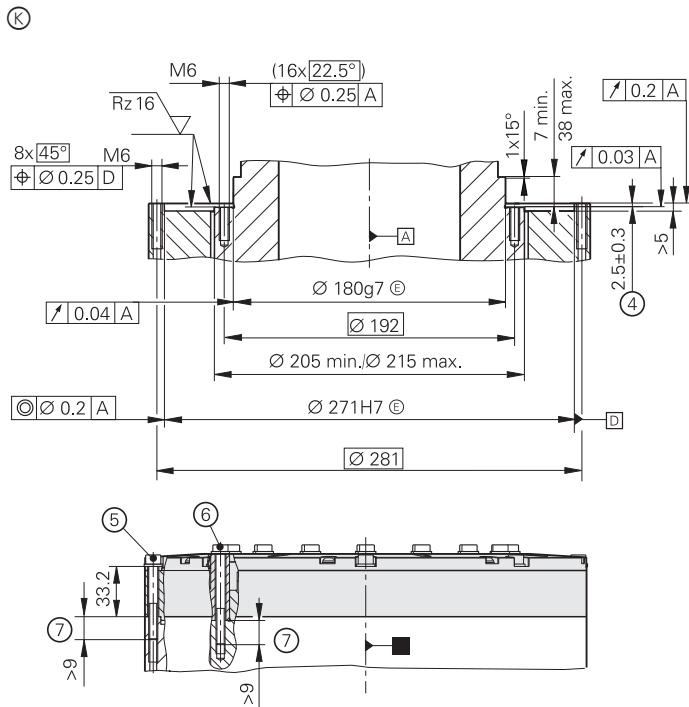

## Shaft coupling via thread

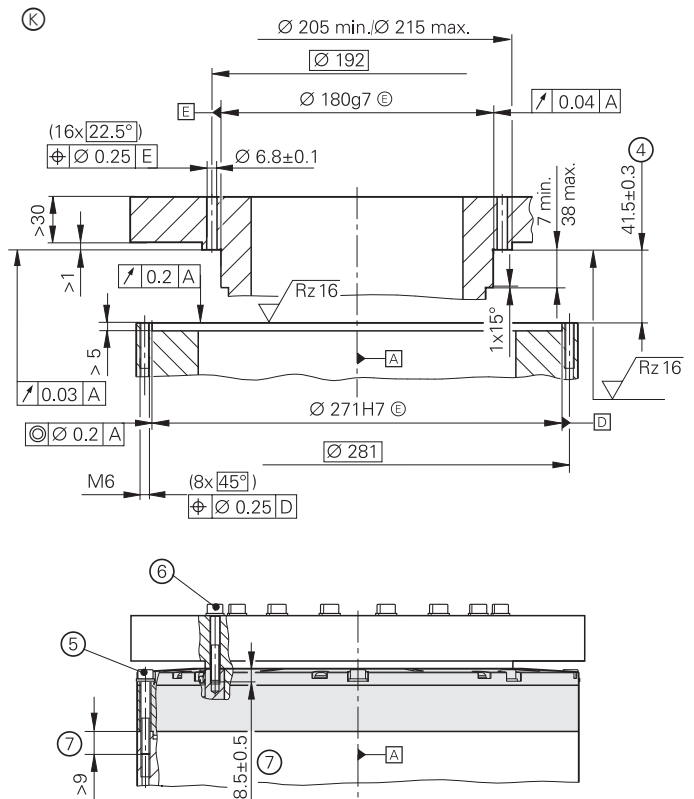

▣ = Bearing of mating shaft

⊙ = Compressed air inlet

⊕ = Required mating dimensions

1 = Mark for 0° position  $\pm 2.5''$

2 = Cable support

3 = Free space for customer

4 = Tolerance specification includes mounting tolerances and thermal expansion. No dynamic movement permitted.

5 = Screw: ISO 4762-M6-8.8.

6 = Screw: ISO 4762-M6-8.8.

7 = Thread engagement

8 = Direction of shaft rotation for output signals as per the interface description

mm



Tolerancing ISO 8015

ISO 2768 - m H

$\leq 6$  mm:  $\pm 0.2$  mm

	<b>Absolute RCN 6310</b> 	<b>RCN 6390F</b>	<b>RCN 6390M</b>
<b>Measuring standard</b>	METALLUR graduation with absolute and incremental track (19998 lines)		
<b>System accuracy</b>	±2"		
Position error per signal period	≤ ±0.3"		
<b>Functional safety</b> for applications up to	<ul style="list-style-type: none"> <li>SIL 2 as per EN 61508 (further basis for testing: EN 61800-5-2)</li> <li>Category 3, PL d as per EN ISO 13849-1:2015</li> </ul>	–	
PFH	≤ 25 · 10 <sup>-9</sup>	–	
Safe position <sup>1)</sup>	<i>Encoder:</i> ±0.22° (safety-related measuring step SM = 0.088°) <i>Mechanical coupling:</i> fault exclusions for loosening of the housing/flange and hollow shaft (page 6)	–	
<b>Interface</b>	EnDat 2.2	Fanuc Serial Interface αi Interface	Mitsubishi high speed interface
Ordering designation	EnDat22	Fanuc05	Mit03-4
Position values/revolution	268435456 (28 bits); <i>Fanuc α Interface:</i> 134217728 (27 bits)		
Electrically permissible speed	≤ 800 rpm for continuous position value		
Clock frequency Calculation time t <sub>cal</sub>	≤ 16 MHz ≤ 5 μs	–	
<b>Electrical connection</b>	Separate adapter cable connectable to encoder via quick disconnect		
Cable length <sup>2)</sup>	≤ 100 m	≤ 50 m	≤ 30 m
Supply voltage	DC 3.6 V to 14 V		
Power consumption <sup>3)</sup> (max.)	3.6 V: ≤ 1.1 W; 14 V: ≤ 1.3 W		
Current consumption (typical)	5 V: 140 mA (without load)		

<sup>1)</sup> Further tolerances might apply in subsequent electronics after position value comparison (contact manufacturer of subsequent electronics).

<sup>2)</sup> With HEIDENHAIN cable; ≤ 8 MHz

<sup>3)</sup> See *General electrical information* in the brochure *Interfaces of HEIDENHAIN encoders*

	<b>Absolute</b> <b>RCN 6310</b>		<b>RCN 6390 F</b>	<b>RCN 6390 M</b>
<b>Shaft</b>	Hollow through shaft D = 180 mm			
Mech. permissible speed	$\leq 200 \text{ rpm}^{4)}$			
Starting torque (at 20 °C)	Typically $\leq 2.0 \text{ Nm}$			
Moment of inertia	<i>Rotor (hollow shaft):</i> $40 \cdot 10^{-3} \text{ kgm}^2$ ; <i>Stator (housing/flange):</i> $52 \cdot 10^{-3} \text{ kgm}^2$			
Radial load (typical)	4.0 N per $\mu\text{m}$ rotor-to-stator radial error			
Permissible axial motion of measured shaft	$\pm 0.3 \text{ mm}^{5)}$			
<b>Natural frequency</b>	$\leq 650 \text{ Hz}$			
<b>Vibration</b> 55 Hz to 1400 Hz <b>Shock</b> 6 ms	$\leq 200 \text{ m/s}^2$ (EN 60068-2-6) $\leq 200 \text{ m/s}^2$ (EN 60068-2-27)			
<b>Operating temperature</b>	0 °C to +50 °C			
<b>Protection</b> EN 60529	IP64			
<b>Mass</b>	$\approx 6.5 \text{ kg}$			

<sup>4)</sup> Higher speeds possible depending on the operating temperature (see *Mechanically permissible speed*)

<sup>5)</sup> Range includes mounting tolerances and thermal expansion. No dynamic motion permitted.

# Mechanically permissible speed

The operating temperature, i.e. the temperature in the vicinity of the angle encoder, influences the permissible rotational speed (see figure). For example, at a working temperature of 50 °C, the max. permissible speed is 200 rpm; at 20 °C it is 500 rpm. Higher speeds are also permissible for short periods (up to 800 rpm). In this case, consultation is required.

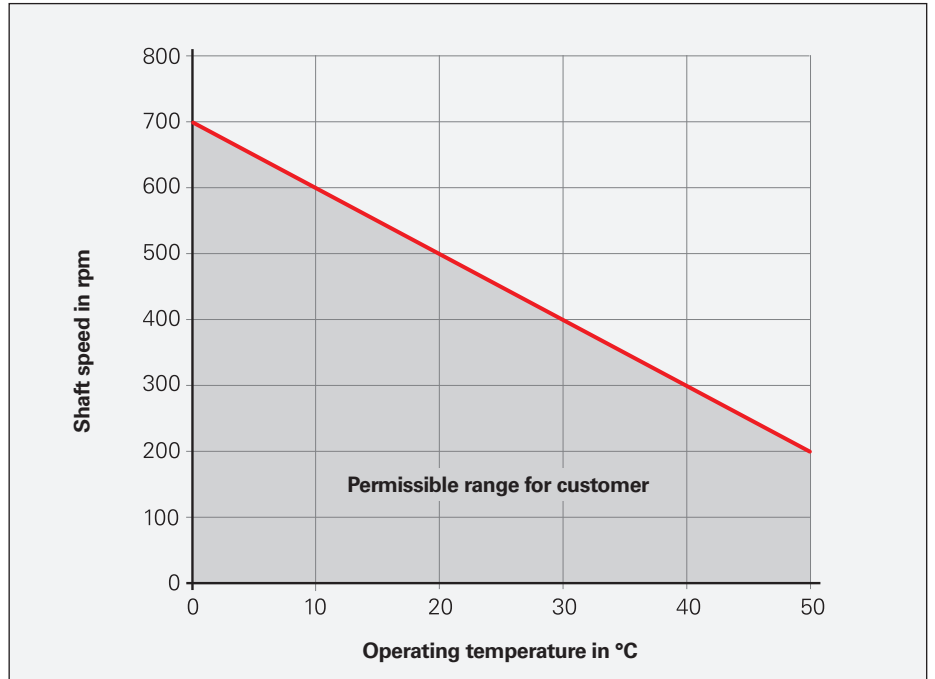

Permissible speed and operating temperature for RCN 6000

# Functional safety

With its RCN 6310 absolute angle encoder, HEIDENHAIN offers the ideal solution for position acquisition for rotational axes in safety-related applications. In conjunction with a safe control, the encoders can be used as single-encoder systems for applications with control category SIL 2 (as per EN 61508) and performance level d'' (as per EN ISO 13849).

Reliable transmission of the position is based on two independently generated absolute position values and on error bits, which are then provided to the safe control. The functions of the encoder can be used for numerous safety functions in the complete system as per EN 61800-5-2.

The RCN 6310 angle encoders provide a safe absolute position value at all times—including immediately after switch-on. Purely serial data transfer takes place via the bidirectional EnDat 2.2 interface.

In addition to the data interface, the mechanical connection of the encoder to the motor is also relevant for safety. Table D16 of the standard for electrical drives, EN 61800-5-2, defines the loosening of the mechanical connection

between the encoder and drive as a fault that requires consideration. Since it cannot be guaranteed that the control will detect such errors, in many cases a fault exclusion for the loosening of the mechanical connection is required.

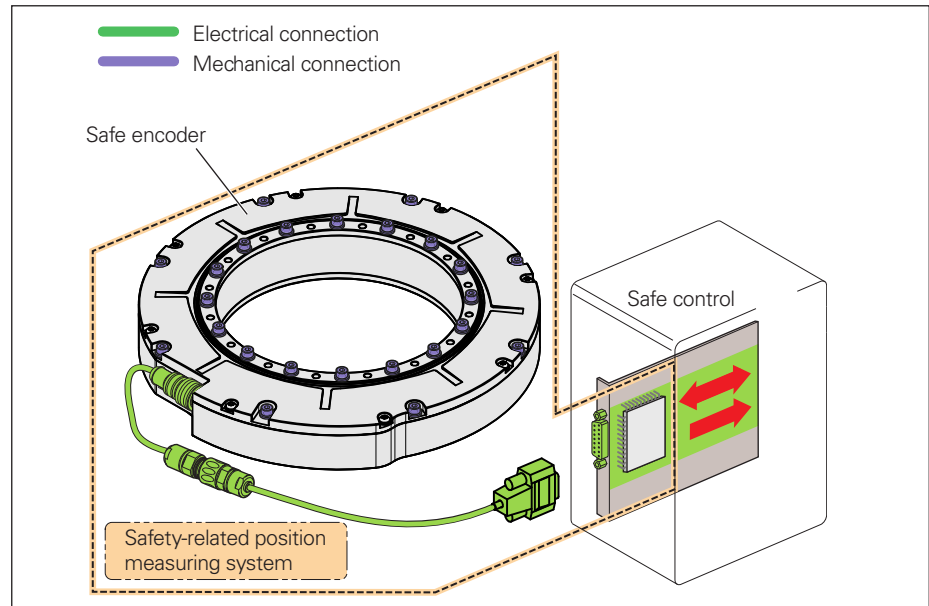

Safety-related position measuring system with mechanical connection and electrical interface

## Fault exclusion against loosening of the mechanical connection

There are different possibilities for attaching the RCN 6000 series that ensure mechanical fault exclusion. Mounting screws are used for mounting the housing and flange, as well as for the shaft coupling.

This way, fault exclusion can be realized for the loosening of the mechanical connection between the encoder and machine shaft or the customer's mounting components. The following torque of the encoder is to be taken into account when designing the mechanical fault exclusion for further connections used exclusively by the customer:

$$M_{Max} = J \cdot \alpha + 20 \text{ Nm}$$

J: Moment of inertia of the encoder (rotor or stator, see Specifications) and of the connection (e.g. connecting web and lifting-eye nut for acceleration via the hollow shaft and shaft coupling by means of these components)

$\alpha$ : max. angular acceleration in the application

Mechanical connection	Fastening <sup>1)</sup>	Safe position for the mechanical coupling <sup>2)</sup>
Housing/flange	M6 ISO 4762 8.8 screws	$\pm 0^\circ$
Hollow shaft Shaft coupling	M6 ISO 4762 8.8 screws	$\pm 0^\circ$

<sup>1)</sup> A suitable anti-rotation lock is to be used for the screw connections (for mounting or service)

<sup>2)</sup> Fault exclusions are given only for the mounting options explicitly stated

# Mounting

## Mounting

The housing of the RCN 6000 is firmly attached to the mounting surface of the machine by means of the mounting flange and the centering collar. The hollow shaft is coupled with the machine shaft by means of through holes or threads.

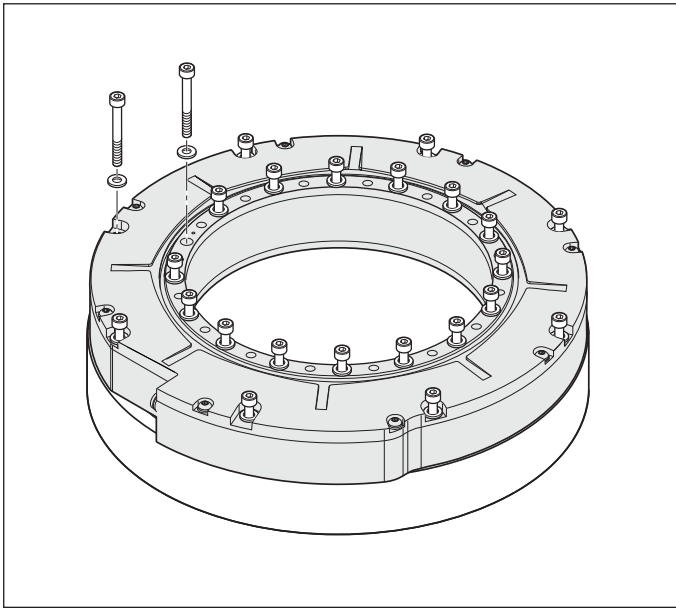

Shaft coupling via through holes

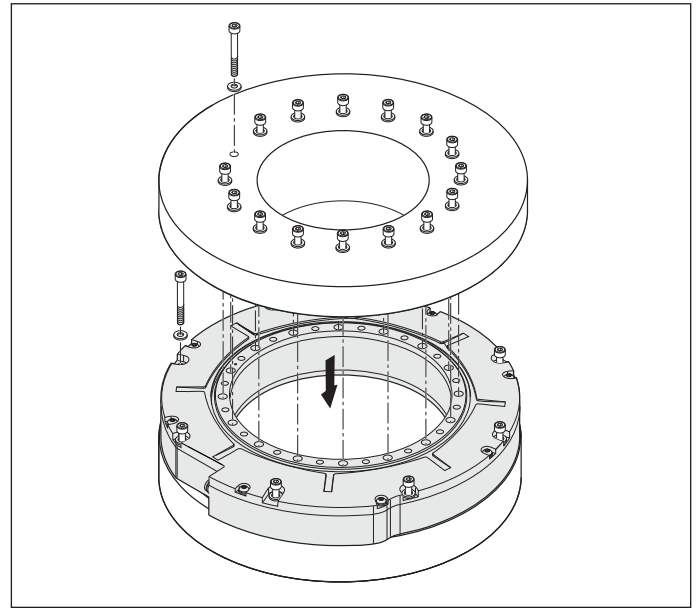

Shaft coupling via threads

### Permissible angular acceleration

1000 rad/s<sup>2</sup>





### Material

The materials listed in the following table must be used for the machine shaft and the mounting components.





	Mating shaft	Mating stator
<b>Material</b>	Ferrous materials (steel/iron casting materials)	
<b>Tensile strength <math>R_m</math></b>	$\geq 600 \text{ N/mm}^2$	$\geq 250 \text{ N/mm}^2$
<b>Shear strength <math>\tau_a</math></b>	$\geq 390 \text{ N/mm}^2$	$\geq 290 \text{ N/mm}^2$
<b>Interface pressure <math>p_G</math></b>	$\geq 660 \text{ N/mm}^2$	$\geq 275 \text{ N/mm}^2$
<b>Elastic modulus <math>E</math></b>	110 000 N/mm <sup>2</sup> to 215 000 N/mm <sup>2</sup>	
<b>Coefficient of thermal expansion <math>\alpha_{\text{therm}}</math> (at 20 °C)</b>	10 · 10 <sup>-6</sup> K <sup>-1</sup> to 17 · 10 <sup>-6</sup> K <sup>-1</sup>	
<b>Mounting temperature</b>	All information on screw connections is given with respect to a mounting temperature of 15 °C to 35 °C	

# Electrical connection

## Cables

<b>PUR adapter cable</b> $\varnothing 4.5 \text{ mm}; 1 \times (4 \times 0.09 \text{ mm}^2) + 4 \times 0.16 \text{ mm}^2; A_P = 2 \times 0.16 \text{ mm}^2$		
<b>Adapter cable</b> with 8-pin M12 coupling (male)		729681-xx
<b>Adapter cable</b> with 15-pin D-sub connector (female)		1119394-xx
<b>PUR adapter cables and connecting cables</b> $\varnothing 6 \text{ mm}; 2 \times (2 \times 0.09 \text{ mm}^2) + 2 \times (2 \times 0.16 \text{ mm}^2); A_P = 2 \times 0.16 \text{ mm}^2$		
<b>Connecting cable</b> with 8-pin M12 connector (female) and 8-pin M12 coupling (male)		1036372-xx
<b>Adapter cable</b> with 8-pin M12 connector (female) and 15-pin D-sub connector (female)		1036521-xx
<b>Adapter cable</b> with 8-pin M12 connector (female) and 15-pin D-sub connector (female)		1036526-xx

## Fanuc/Mitsubishi adapter cables and connecting cables

<b>PUR adapter cable</b> $\varnothing 4.5 \text{ mm}; (4 \times 0.09 \text{ mm}^2) + (4 \times 0.16 \text{ mm}^2); A_P = 2 \times 0.16 \text{ mm}^2$	<b>Fanuc</b>	<b>Mitsubishi</b>
<b>Adapter cable</b> with • Fanuc connector (female) or • 10-pin Mitsubishi connector (female)		1119918-xx      1119925-xx
<b>Adapter cable</b> with 20-pin Mitsubishi connector (male)		–      1119920-xx
<b>Adapter cable</b> with 8-pin M12 coupling (male)		729681-xx
<b>PUR connecting cable</b> $\varnothing 6 \text{ mm}; 2(2 \times 0.09 \text{ mm}^2) + 2(2 \times 0.16 \text{ mm}^2); A_P = 2 \times 0.16 \text{ mm}^2$	<b>Fanuc</b>	<b>Mitsubishi</b>
<b>Connecting cable</b> with 8-pin M12 connector (female) and 8-pin M12 coupling (male)		1036372-xx

$A_P$ : Cross section of power supply lines

$\varnothing$ : Cable diameter (for bending radii, see the *Interfaces of HEIDENHAIN Encoders* brochure)

**Note for safety-related applications:** Only completely assembled HEIDENHAIN cables are qualified.

Be sure to exchange connectors or modify cables only after consultation with HEIDENHAIN Traunreut.

For more cables, see the brochure *Angle Encoders with Integral Bearing*.

# HEIDENHAIN

**DR. JOHANNES HEIDENHAIN GmbH**

Dr.-Johannes-Heidenhain-Straße 5

**83301 Traunreut, Germany**

☎ +49 8669 31-0

FAX +49 8669 32-5061

E-mail: info@heidenhain.de

**www.heidenhain.de**

This Product Information supersedes all previous editions, which thereby become invalid. The basis for ordering from HEIDENHAIN is always the Product Information document edition valid when the order is made.



### Further information:

Adhere to the information in the following documents to ensure the correct and intended operation of the encoder:

- Brochure: *Angle Encoders with Integral Bearing* 591109
- Brochure: *Interfaces of HEIDENHAIN Encoders* 1078628
- Brochure: *Cables and Connectors* 1206103
- Mounting instructions: *RCN 6000* 1234453
- Technical Information: *Safety-Related Position Measuring Systems* 596632

For implementation in a control:

- Specifications for Safe Control 533095

For brochures and product information documents, visit **www.heidenhain.de**.