



HEIDENHAIN

araxe

72, rue Yves le Coz
78000 VERSAILLES

tél : 01 30 21 48 49

fax : 01 39 51 16 33

<http://www.araxe.com>

contact@araxe.com

HEIDENHAIN

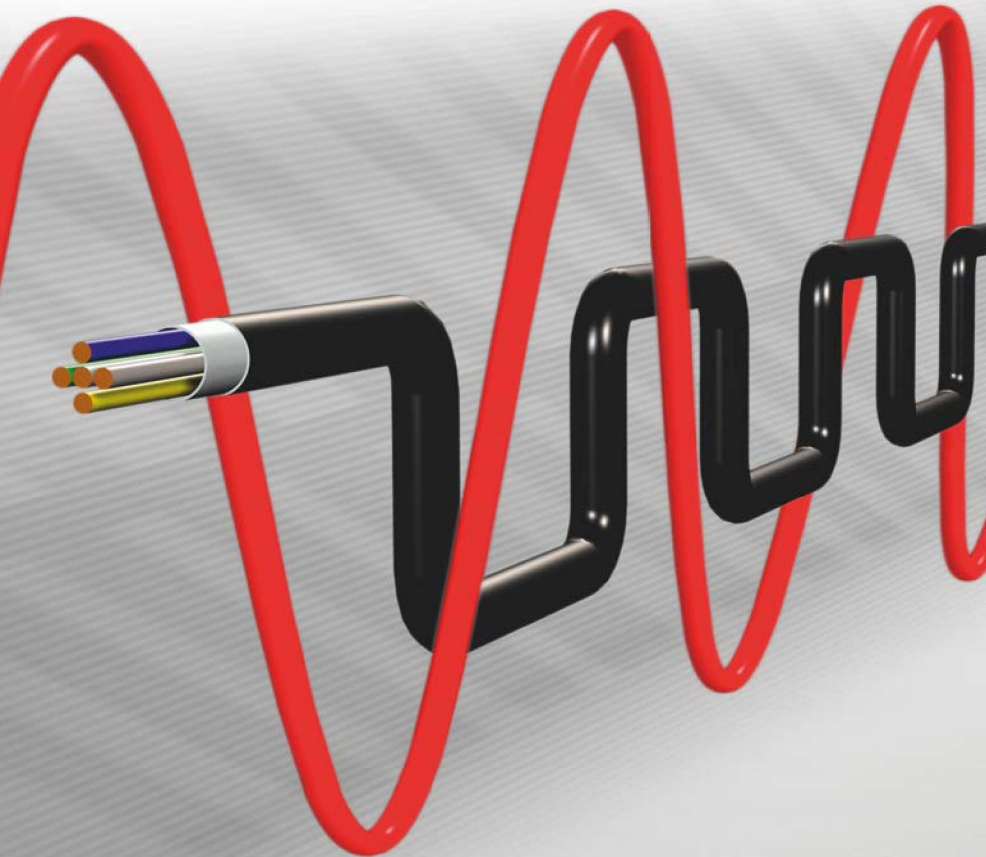

Interfaces

of HEIDENHAIN Encoders

March 2015

Interfaces

As well-defined transitions between encoders and subsequent electronics, interfaces ensure the reliable exchange of information.

HEIDENHAIN offers encoders with interfaces for many common subsequent electronics. The interface possible in each respective case depends, among other things, on the measuring method used by the encoder.

Measurement procedure

In the **incremental measuring method** the position information is obtained **by counting** the individual increments (measuring steps) from some point of origin. Since an absolute reference is necessary in order to determine the positions, a reference-mark signal is output as well. As a general rule, encoders that operate with the incremental measuring method provide **incremental signals**. Some incremental encoders with integrated interface electronics have a counting function: Once the reference mark is traversed, an absolute position value is formed and transmitted via a serial interface.

Note

Specialized encoders can have other interface properties, such as regarding the shielding.

With the **absolute measuring method** the absolute position information is gained directly **from the graduation of the measuring standard**. The position value is available from the encoder immediately upon switch-on and can be called at any time by the subsequent electronics.

Encoders that operate with the absolute measuring method output **position values**. Some interfaces provide incremental signals as well.

Absolute encoders do not require a reference run, which is advantageous particularly in concatenated manufacturing systems, transfer lines, or machines with numerous axes. Also, they are highly resistant to EMC interference.

Interface electronics

Interface electronics from HEIDENHAIN adapt the encoder signals to the interface of the subsequent electronics. They are used when the subsequent electronics cannot directly process the output signals from HEIDENHAIN encoders, or if additional interpolation of the signals is necessary.

You can find more detailed information in the *Interface Electronics* Product Overview.

This catalog supersedes all previous editions, which thereby become invalid. The basis for ordering from HEIDENHAIN is always the catalog edition valid when the contract is made.

Contents

Incremental signals				
Sinusoidal signals	1 V_{pp}	Voltage signals, can be highly interpolated		4
	11 μA_{pp}	Current signals, can be interpolated		6
Square-wave signals	TTL	RS 422, typically 5 V		7
	HTL	Typically 10 V to 30 V		10
	HTLs	Typically 10 V to 30 V, without inverted signals		
Position values				
Serial interfaces	EnDat	Bidirectional interface	With incremental signals	12
			Without incremental signals	
	Siemens	Company-specific information	Without incremental signals	15
	Fanuc	Company-specific information	Without incremental signals	
	Mitsubishi	Company-specific information	Without incremental signals	
	Panasonic	Company-specific information	Without incremental signals	
	Yaskawa	Company-specific information	Without incremental signals	
	PROFIBUS-DP	Fieldbus	Without incremental signals	16
	PROFINET IO	Ethernet-based fieldbus	Without incremental signals	18
	SSI	Synchronous serial interface	With incremental signals	20
Other signals				
Commutation signals	Block commutation			22
	Sinusoidal commutation			23
Limit/Homing	Limit switches			24
	Position detection			25
Further Information				
Interface electronics				26
Diagnostic and testing equipment				28
General electrical information				32

Incremental signals

~ 1 V_{PP} sinusoidal signals

HEIDENHAIN encoders with ~ 1 V_{PP} interface provide voltage signals that can be highly interpolated.

The sinusoidal **incremental signals** A and B are phase-shifted by 90° elec. and have amplitudes of typically 1 V_{PP}. The illustrated sequence of output signals—with B lagging A—applies for the direction of motion shown in the dimension drawing.

The **reference mark signal** R has a usable component G of approx. 0.5 V. Next to the reference mark, the output signal can be reduced by up to 1.7 V to a quiescent value H. This must not cause the subsequent electronics to overdrive. In the lowered signal level, too, signal peaks can appear with the amplitude G.

The data on **signal amplitude** apply when the supply voltage given in the specifications is connected to the encoder. It refers to a differential measurement at the 120 ohm terminating resistor between the associated outputs. The signal amplitude decreases with increasing frequency. The **cutoff frequency** indicates the scanning frequency up to which a certain percentage of the original signal amplitude is maintained:

- -3 dB ≅ 70 % of the signal amplitude
- -6 dB ≅ 50 % of the signal amplitude

The data in the signal description apply to motions at up to 20 % of the -3 dB-cutoff frequency.

Interpolation/resolution/measuring step

The output signals of the 1 V_{PP} interface are usually interpolated in the subsequent electronics in order to attain sufficiently high resolutions. For **velocity control**, interpolation factors are commonly over 1000 in order to receive usable information even at low rotational or linear velocities.

Measuring steps for **position measurement** are recommended in the specifications. For special applications, other resolutions are also possible.

Short-circuit stability

A short circuit of outputs is not a permissible operating condition. Exception: For encoders with a 5V DC ± 5 % supply voltage, a temporary short circuit of one signal output to 0 V or U_P does not cause encoder failure.

Short circuit at	20 °C	125 °C
One output	< 3 min	< 1 min
All outputs	< 20 s	< 5 s

Interface	Sinusoidal voltage signals ~ 1 V _{PP}
Incremental signals	Two nearly sinusoidal signals A and B Signal amplitude M: 0.6 to 1.2 V _{PP} ; typically 1 V _{PP} Asymmetry P - N /2M: ≤ 0.065 Amplitude ratio M _A /M _B : 0.8 to 1.25 Phase angle φ ₁ + φ ₂ /2: 90° ± 10° elec.
Reference mark signal	One or several signal peaks R Usable component G: ≥ 0.2 V Quiescent value H: ≤ 1.7 V Switching threshold E, F: 0.04 V to 0.68 V Zero crossovers K, L: 180° ± 90° elec.
Connecting cables	Shielded HEIDENHAIN cable e.g. PUR [4(2 × 0.14 mm ²) + (4 × 0.5 mm ²)] Cable length: Max. 150 m at 90 pF/m distributed capacitance Propagation time: 6 ns/m

These values can be used for dimensioning of the subsequent electronics. Any limited tolerances in the encoders are listed in the specifications. For encoders without integral bearing, reduced tolerances are recommended for initial operation (see the mounting instructions).

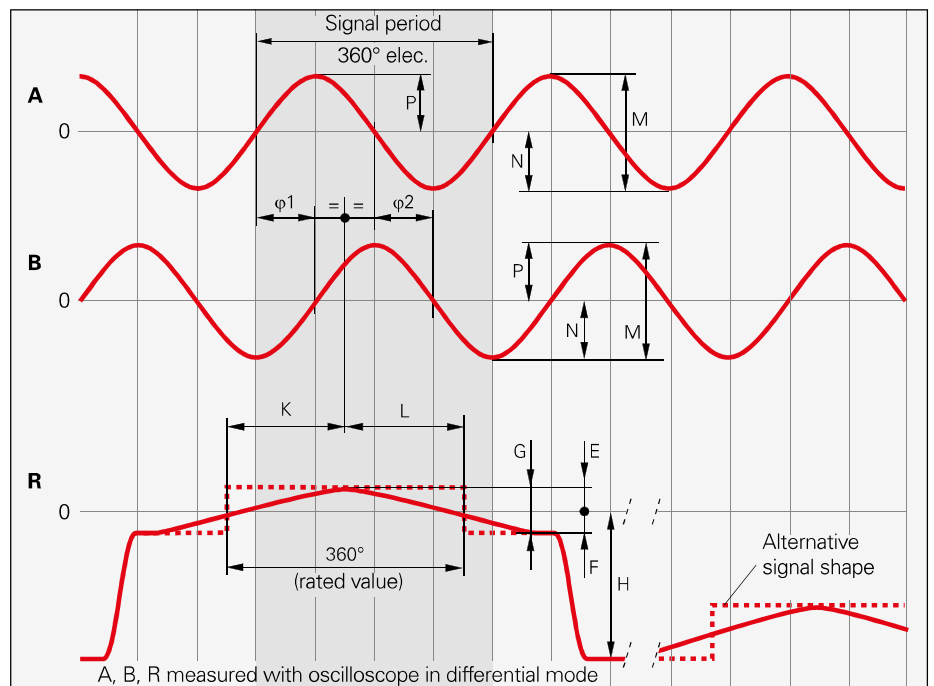

Cut-off frequency

Typical signal amplitude curve with respect to the output frequency (depends on encoder)

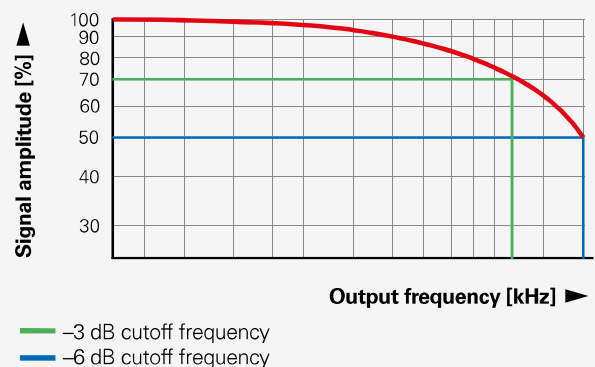

Monitoring of the incremental signals

The following sensitivity levels are recommended for monitoring the signal amplitude M :

Lower threshold: $0.30 V_{PP}$
Upper threshold: $1.35 V_{PP}$

The height of the incremental signals can be monitored, for example by the length of the resulting position indicator: The oscilloscope shows the output signals A and B as a Lissajous figure in the XY graph. Ideal sinusoidal signals produce a circle with the diameter M . In this case the position indicator r shown corresponds to $\frac{1}{2}M$. The formula is therefore

$$r = \sqrt{(A^2 + B^2)}$$

with the condition $0.3 V < 2r < 1.35 V$.

Input circuitry of subsequent electronics

Dimensioning

Operational amplifier, e.g. MC 34074

$Z_0 = 120 \Omega$

$R_1 = 10 \text{ k}\Omega$ and $C_1 = 100 \text{ pF}$

$R_2 = 34.8 \text{ k}\Omega$ and $C_2 = 10 \text{ pF}$

$U_B = \pm 15 \text{ V}$

U_1 approx. U_0

-3 dB cutoff frequency of circuitry

$\approx 450 \text{ kHz}$

$\approx 50 \text{ kHz}$ with $C_1 = 1000 \text{ pF}$
and $C_2 = 82 \text{ pF}$

The circuit variant for 50 kHz does reduce the bandwidth of the circuit, but in doing so it improves its noise immunity.

Circuit output signals

$U_a = 3.48 V_{PP}$ typically

Gain 3.48

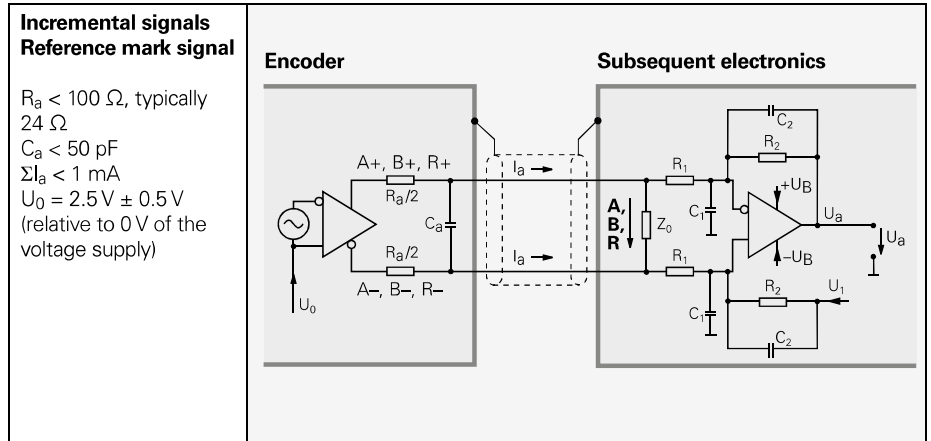
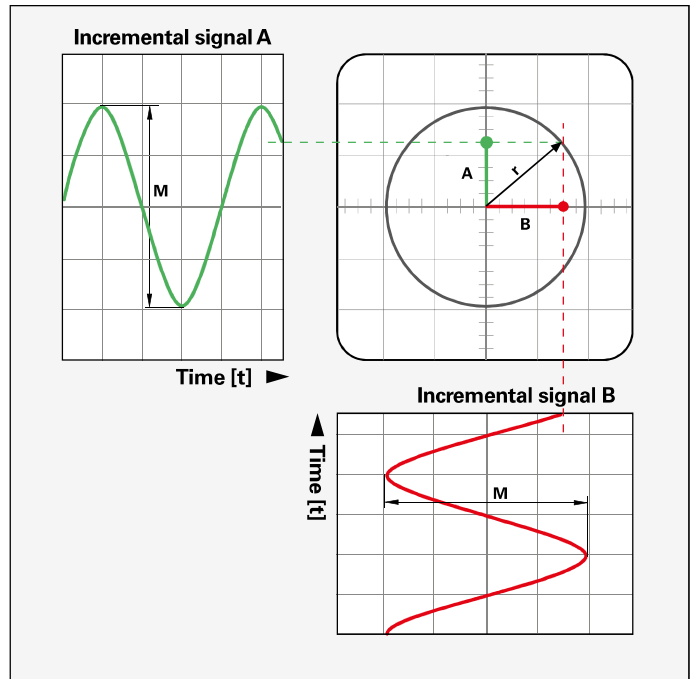

Input circuitry of subsequent electronics for high signal frequencies

For encoders with high signal frequencies (e.g. LIP 281), a special input circuitry is required.

Dimensioning

Operational amplifier, e.g. AD 8138

$Z_0 = 120 \Omega$

$R_1 = 681 \Omega$; $R_2 = 1 \text{ k}\Omega$; $R_3 = 464 \Omega$

$C_0 = 15 \text{ pF}$; $C_1 = 10 \text{ pF}$

$+U_B = 5 \text{ V}$; $-U_B = 0 \text{ V}$ or -5 V

-3 dB cutoff frequency of circuitry

$\approx 10 \text{ MHz}$

Circuit output signals

$U_a = 1.47 V_{PP}$ typically

Gain 1.47

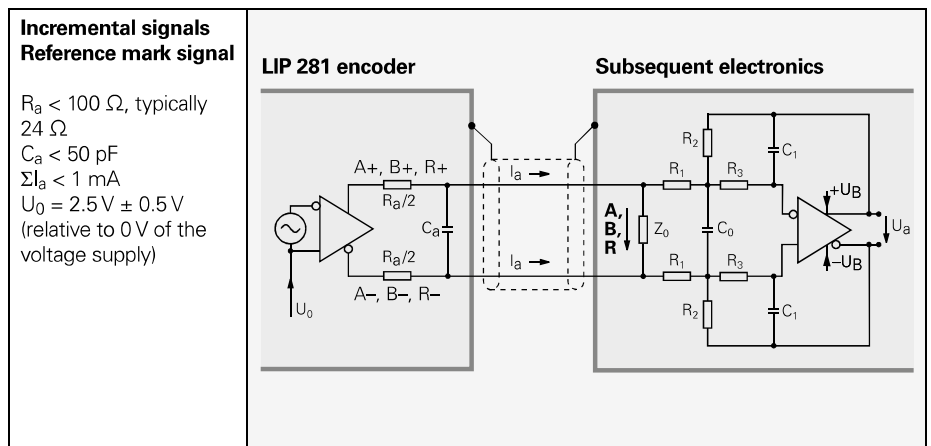

Incremental signals

~ 11 μA_{PP} sinusoidal signals

HEIDENHAIN encoders with ~ 11 μA_{PP} interface provide current signals. They are intended for connection to ND position display units or EXE pulse-shaping electronics from HEIDENHAIN.

The sinusoidal **incremental signals** I_1 and I_2 are phase-shifted by 90° elec. and have signal levels of typically 11 μA_{PP} .

The illustrated sequence of output signals—with I_2 lagging I_1 —applies to the direction of motion shown in the dimension drawing, and for retracting plungers of length gauges.

The **reference mark signal** I_0 has a usable component G of approx. 5.5 μA .

The data on **signal amplitude** apply when the supply voltage given in the *Specifications* is connected at the encoder. They refer to a differential measurement between the associated outputs. The signal amplitude decreases with increasing frequency. The **cutoff frequency** indicates the scanning frequency up to which a certain percentage of the original signal amplitude is maintained:

- -3 dB cutoff frequency:
70 % of the signal amplitude
- -6 dB-cutoff frequency:
50 % of the signal amplitude

Interpolation/resolution/measuring step

The output signals of the 11 μA_{PP} interface are usually interpolated in the subsequent electronics—ND position displays or EXE pulse-shaping electronics from HEIDENHAIN—in order to attain sufficiently high resolutions.

Interface	Sinusoidal current signals ~ 11 μA_{PP}
Incremental signals	Two nearly sinusoidal signals I_1 and I_2 Signal amplitude M: 7 to 16 μA_{PP} /typically 11 μA_{PP} Asymmetry IP – NI/2M: ≤ 0.065 Amplitude ratio M_A/M_B : 0.8 to 1.25 Phase angle $ \varphi_1 + \varphi_2 /2$: $90^\circ \pm 10^\circ$ elec.
Reference mark signal	One or more signal peaks I_0 Usable component G: 2 μA to 8.5 μA Switching threshold E, F: $\geq 0.4 \mu\text{A}$ Zero crossovers K, L: $180^\circ \pm 90^\circ$ elec.
Connecting cables	Shielded HEIDENHAIN cable PUR [3(2 · 0.14 mm ²) + (2 · 1 mm ²)] Cable length Propagation time Max. 30 m with 90 pF/m distributed capacitance 6 ns/m

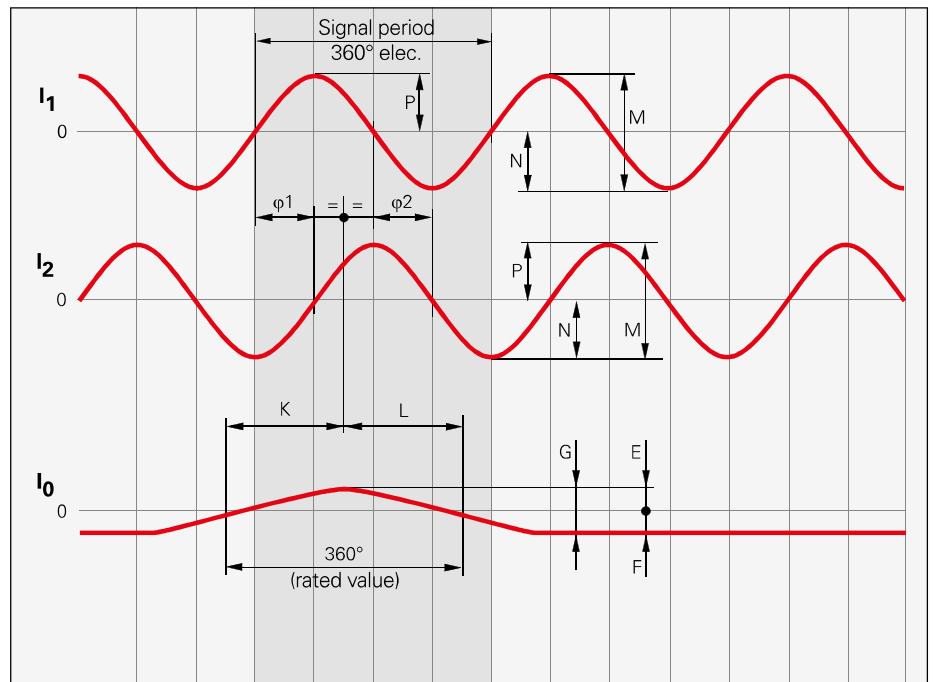

□TTL square-wave signals

HEIDENHAIN encoders with □TTL interface incorporate electronics that digitize sinusoidal scanning signals with or without interpolation.

The **incremental signals** are transmitted as the square-wave pulse trains U_{a1} and U_{a2} , phase-shifted by 90° elec. The **reference mark signal** consists of one or more reference pulses U_{a0} , which are gated with the incremental signals. In addition, the integrated electronics produce their **inverted signals** $\overline{U_{a1}}$, $\overline{U_{a2}}$ and $\overline{U_{a0}}$ for noise-proof transmission. The illustrated sequence of output signals—with U_{a2} lagging U_{a1} —applies to the direction of motion shown in the dimension drawing.

The **fault-detection signal** $\overline{U_{aS}}$ indicates fault conditions such as breakage of the power line or failure of the light source. It can be used for such purposes as machine shut-off during automated production.

The distance between two successive edges of the incremental signals U_{a1} and U_{a2} through 1-fold, 2-fold or 4-fold evaluation is one **measuring step**.

The subsequent electronics must be designed to detect each edge of the square-wave pulse. The minimum **edge separation a** stated in the Specifications applies for the specified input circuit with a cable length of 1 m and refers to a measurement at the output of the differential line receiver.

Note

Not all encoders output a reference mark signal, fault-detection signal, or their inverted signals. Please see the connector layout for this.

Interface	Square-wave signals □TTL
Incremental signals	Two TTL square-wave signals U_{a1}, U_{a2} and their inverted signals $\overline{U_{a1}}$, $\overline{U_{a2}}$
Reference mark signal Pulse width Delay time	One or more TTL square-wave pulses U_{a0} and their inverted pulses $\overline{U_{a0}}$ 90° elec. (other widths available on request) $ t_d \leq 50$ ns
Fault-detection signal Pulse width	One TTL square-wave pulse $\overline{U_{aS}}$ Improper function: LOW (upon request: U_{a1}/U_{a2} high impedance) Proper function: HIGH $t_S \geq 20$ ms
Signal amplitude	Differential line driver as per EIA standard RS-422
Permissible load	$Z_0 \geq 100 \Omega$ Between associated outputs $ I_L \leq 20$ mA Max. load per output (ERN 1x23: 10 mA) $C_{load} \leq 1000$ pF With respect to 0 V Outputs protected against short circuit to 0 V
Switching times (10 % to 90 %)	$t_+ / t_- \leq 30$ ns (10 ns typically) with 1 m cable and recommended input circuitry
Connecting cables Cable length Propagation time	Shielded HEIDENHAIN cable e.g. PUR $[4(2 \times 0.14 \text{ mm}^2) + (4 \times 0.5 \text{ mm}^2)]$ Max. 100 m ($\overline{U_{aS}}$ max. 50 m) at distributed capacitance 90 pF/m Typically 6 ns/m

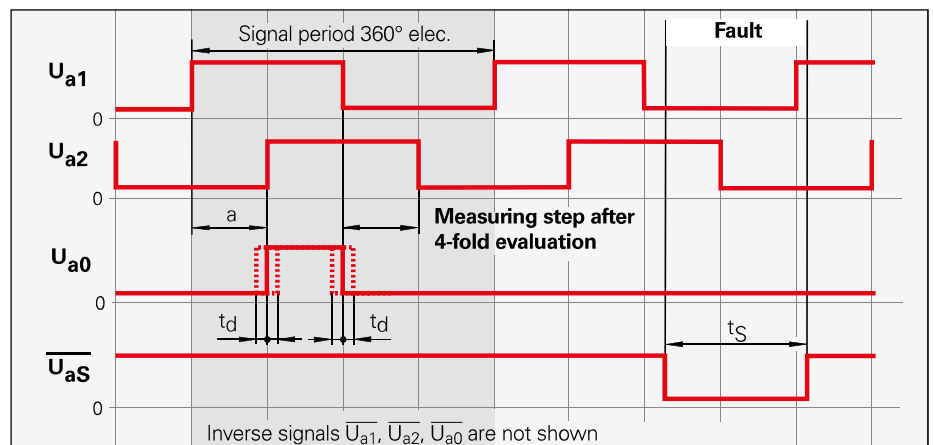

Clocked output signals are typical for encoders and interpolation electronics with 5-fold interpolation (or greater). They derive the edge separation from an internal clock source. At the same time, the clock frequency determines the permissible input frequency of the incremental signals (1 V_{PP} or 11 μA_{PP}) and the resulting maximum permissible traversing velocity or shaft speed:

$$a_{nom} = \frac{1}{4 \cdot IPF \cdot fe_{nom}}$$

a_{nom} Nominal edge separation
 IPF Interpolation factor
 fe_{nom} Nominal input frequency

The tolerances of the internal clock source have an influence on the edge separation a of the output signal and the input frequency fe, thereby influencing the traversing velocity or shaft speed.

The data for edge separation already takes these tolerances into account with 5%: Not the nominal edge separation is indicated, but rather the minimum edge separation a_{min}.

On the other hand, the maximum permissible input frequency must consider a tolerance of at least 5%. This means that the maximum permissible traversing velocity or shaft speed is also reduced accordingly.

Encoders and interpolation electronics without interpolation in general **do not have clocked output signals**. The minimum edge separation a_{min} that occurs at the maximum possible input frequency is stated in the specifications. If the input frequency is reduced, the edge separation increases correspondingly.

Cable-dependent differences in the propagation time additionally reduce the edge separation by 0.2 ns per meter of cable. To prevent counting errors, a safety margin of 10% must be considered, and the subsequent electronics so designed that they can process as little as 90% of the resulting edge separation.

Please note:

The max. permissible **shaft speed** or **traversing velocity** must never be exceeded, since this would result in an irreversible counting error.

Calculation example 1

LIDA 400 linear encoder

Requirements: display step 0.5 μm, traversing velocity 1 m/s, output signals TTL, cable length to subsequent electronics 25 m.

What minimum edge separation must the subsequent electronics be able to process?

Selection of the interpolation factor

20 μm grating period : 0.5 μm display step = 40-fold subdivision
 Evaluation in the subsequent electronics 4-fold

Interpolation

10-fold

Selection of the edge separation

Traversing velocity 60 m/min (corresponds to 1 m/s)
 + tolerance value 5% 63 m/min

Select in specifications:

Next LIDA 400 version 120 m/min (from specifications)

Minimum edge separation

0.22 μs (from specifications)

Determining the edge separation that the subsequent electronics must process

Subtract cable-dependent differences in the propagation time 0.2 ns per meter

For cable length = 25 m 5 ns

Resulting edge separation 0.215 μs

Subtract 10% safety margin 0.022 μs

Minimum edge separation for the subsequent electronics 0.193 μs

Calculation example 2

ERA 4000 angle encoder with 32 768 lines

Requirements: measuring step 0.1" ; output signals TTL (IBV external interface electronics necessary), cable length from IBV to subsequent electronics = 20 m, minimum edge separation that the subsequent electronics can process = 0.5 μs (input frequency = 2 MHz).

What rotational speed is possible?

Selection of the interpolation factor

32 768 lines corresponds to 40" signal period
 Signal period 40" : measuring step 0.1" = 400-fold subdivision

Evaluation in the subsequent electronics 4-fold

Interpolation in the IBV

100-fold

Calculation of the edge separation

Permissible edge separation of the subsequent electronics 0.5 μs

This corresponds to 90% of the resulting edge separation

Therefore: Resulting edge separation 0.556 μs

Subtract cable-dependent differences in the propagation time 0.2 ns per meter

For cable length = 20 m 4 ns

Minimum edge separation IBV 102 ≥ 0.56 μs

Selecting the input frequency

According to the Product Information, the input frequencies and therefore the edge separations a of the IBV 102 can be set.

Next suitable edge separation 0.585 μs

Input frequency at 100-fold interpolation 4 kHz

Calculating the permissible shaft speed

Subtract 5% tolerance 3.8 kHz

This is 3800 signals per second or 228000 signals per minute.

Meaning for 32 768 lines of the ERA 4000:

Max. permissible rotational speed 6.95 rpm

The permissible **cable length** for transmission of the TTL square-wave signals to the subsequent electronics depends on the edge separation a . It is at most 100 m, or 50 m for the fault detection signal. This requires, however, that the voltage supply (see *Specifications*) be ensured at the encoder. The sensor lines can be used to measure the voltage at the encoder and, if required, correct it with an automatic control system (remote sense power supply).

Greater cable lengths can be provided upon consultation with HEIDENHAIN.

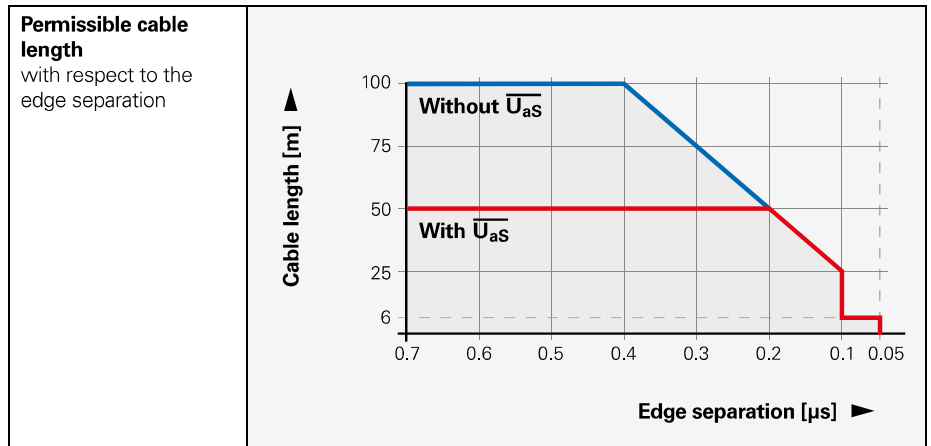

Input circuitry of subsequent electronics

Dimensioning

IC_1 = Recommended differential line receiver
 DS 26 C 32 AT
 Only for $a > 0.1 \mu s$:
 AM 26 LS 32
 MC 3486
 SN 75 ALS 193

$R_1 = 4.7 \text{ k}\Omega$
 $R_2 = 1.8 \text{ k}\Omega$
 $Z_0 = 120 \Omega$
 $C_1 = 220 \text{ pF}$ (serves to improve noise immunity)

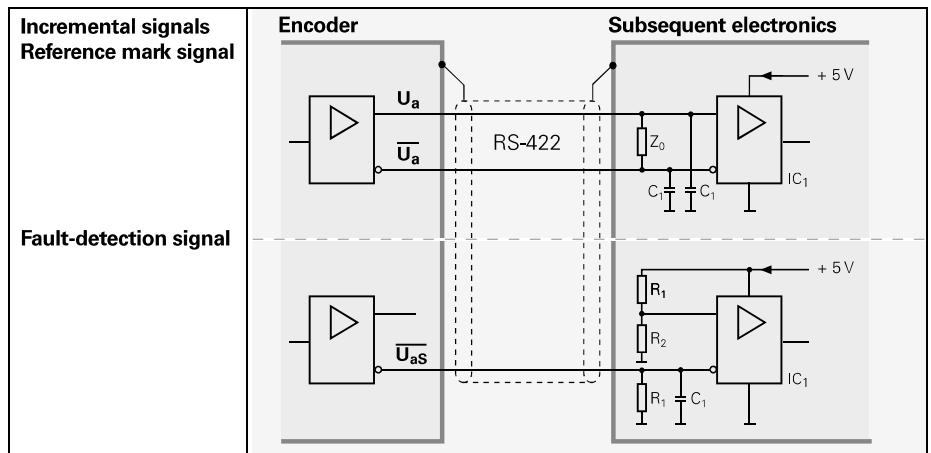

Incremental signals

HTL square-wave signals

HEIDENHAIN encoders with HTL interface incorporate electronics that digitize sinusoidal scanning signals with or without interpolation.

The **incremental signals** are transmitted as the square-wave pulse trains U_{a1} and U_{a2} , phase-shifted by 90° elec. The **reference mark signal** consists of one or more reference pulses U_{a0} , which are gated with the incremental signals. In addition, the integrated electronics produce their **inverse signals** $\overline{U_{a1}}$, $\overline{U_{a2}}$ and $\overline{U_{a0}}$ for noise-proof transmission (does not apply to HTLs).

The illustrated sequence of output signals—with U_{a2} lagging U_{a1} —applies to the direction of motion shown in the dimension drawing.

The **fault-detection signal** $\overline{U_{aS}}$ indicates fault conditions such as failure of the light source. It can be used for such purposes as machine shut-off during automated production.

The distance between two successive edges of the incremental signals U_{a1} and U_{a2} through 1-fold, 2-fold or 4-fold evaluation is one **measuring step**.

The subsequent electronics must be designed to detect each edge of the square-wave pulse. The minimum **edge separation a** stated in the *specifications* refers to a measurement at the output of the given differential input circuit. To prevent counting errors, the subsequent electronics should be designed so that they can process as little as 90 % of the edge separation a.

The maximum permissible **shaft speed** or **traversing velocity** must never be exceeded.

The permissible **cable length** for incremental encoders with HTL signals depends on the output frequency, the effective supply voltage, and the operating temperature of the encoder.

The **current requirement** of encoders with HTL output signals depends on the output frequency and the cable length to the subsequent electronics.

Interface	HTL, HTLs square-wave signals	
Incremental signals	Two HTL square-wave signals U_{a1} , U_{a2} and their inverse signals $\overline{U_{a1}}$, $\overline{U_{a2}}$ (HTLs without U_{a1} , U_{a2})	
Reference mark signal	One or more HTL square-wave pulses U_{a0} and their inverted pulses $\overline{U_{a0}}$ (HTLs without $\overline{U_{a0}}$)	
Pulse width	90° elec. (other widths available on request)	
Delay time	$ t_d \leq 50$ ns	
Fault-detection signal	One HTL square-wave pulse $\overline{U_{aS}}$	
Pulse width	Improper function: LOW Proper function: HIGH $t_S \geq 20$ ms	
Signal level	$U_H \geq 21$ V at $-I_H = 20$ mA $U_L \leq 2.8$ V at $I_L = 20$ mA	With supply voltage $U_P = 24$ V, without cable
Permissible load	$ I_L \leq 100$ mA $C_{load} \leq 10$ nF	Max. load per output, (except $\overline{U_{aS}}$) With respect to 0 V Outputs short-circuit proof for max. 1 minute to 0 V and U_P (except $\overline{U_{aS}}$)
Switching times (10 % to 90 %)	$t_r/t_f \leq 200$ ns (except $\overline{U_{aS}}$) with 1 m cable and recommended input circuitry	
Connecting cables	HEIDENHAIN cable with shielding e.g. PUR [4(2 × 0.14 mm ²) + (4 × 0.5 mm ²)] Max. 300 m (HTLs max. 100 m) at 90 pF/m distributed capacitance 6 ns/m	
Cable length		
Propagation time		

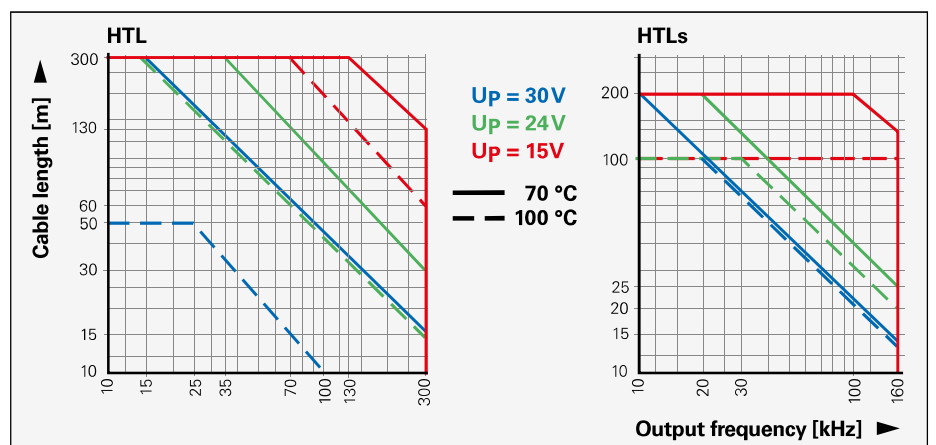
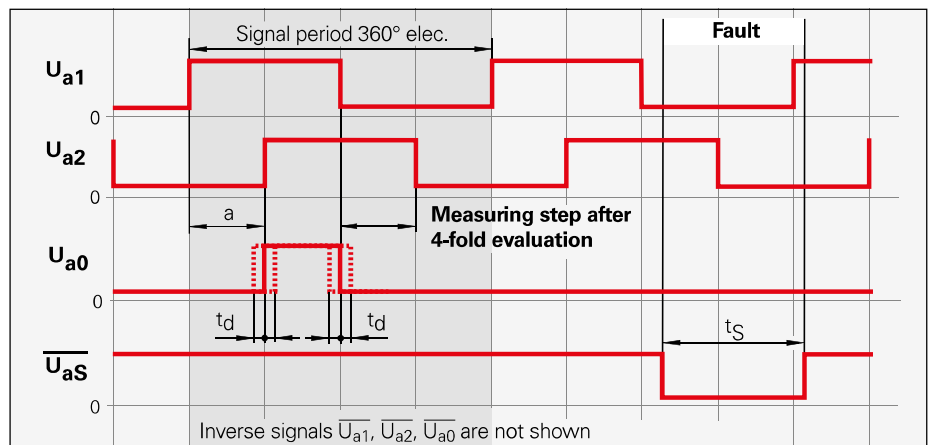

**Input circuitry of subsequent electronics
HTL**

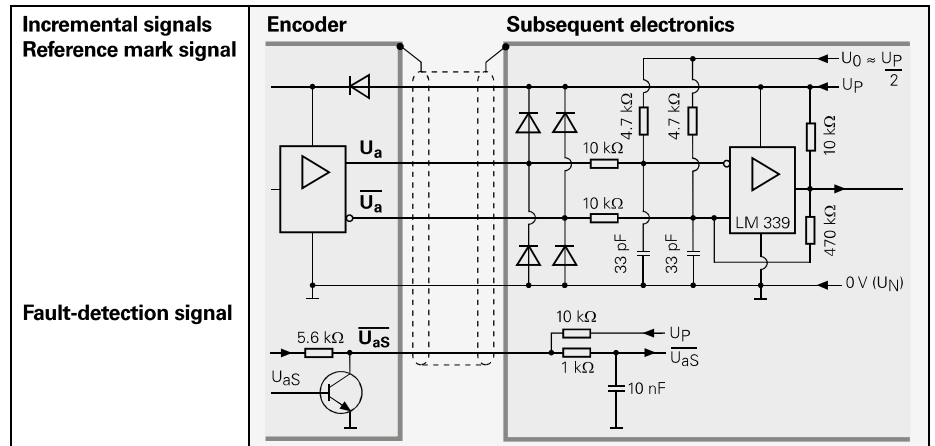

HTLs

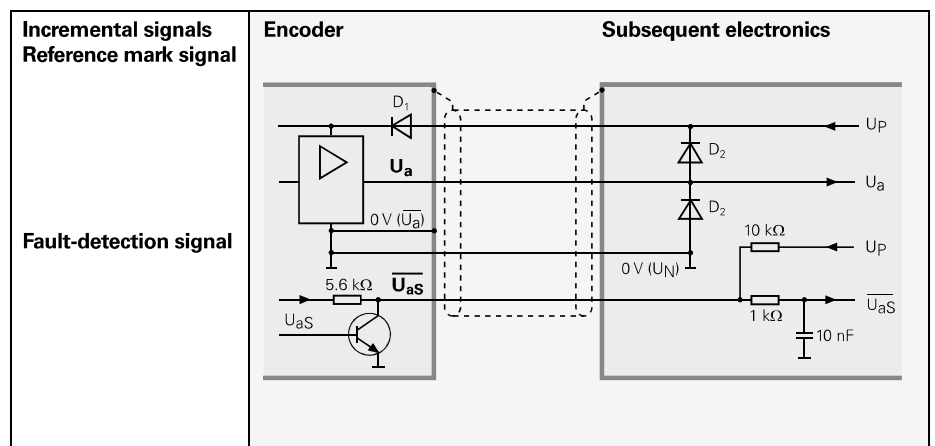

Position values

EnDat serial interface

The EnDat interface is a digital, **bidirectional** interface for encoders. It is capable both of transmitting **position values** as well as transmitting or updating information stored in the encoder, or of saving new information. Thanks to the **serial transmission method**, only **four signal lines** are required. The data is transmitted in **synchronism** with the clock signal from the subsequent electronics. The type of transmission (position values, parameters, diagnostics, etc.) is selected through mode commands that the subsequent electronics send to the encoder. Some functions are available only with EnDat 2.2 mode commands.

History and compatibility

The EnDat 2.1 interface available since the mid-90s has since been upgraded to the EnDat 2.2 version (recommended for new applications). EnDat 2.2 is compatible in its communication, command set and time conditions with version 2.1, but also offers significant advantages. It makes it possible, for example, to transfer additional data (e.g. sensor values, diagnostics, etc.) with the position value without sending a separate request for it. This permits support of additional encoder types (e.g. with battery buffer, incremental encoders, etc.). The interface protocol was expanded and the time conditions (clock frequency, processing time, recovery time) were optimized.

Supported encoder types

The following encoder types are currently supported by the EnDat 2.2 interface (this information can be read out from the encoder's memory area):

- Incremental linear encoder
- Absolute linear encoder
- Rotational incremental singleturn encoder
- Rotational absolute singleturn encoder
- Multiturn rotary encoder
- Multiturn rotary encoder with battery buffer

In some cases, parameters must be interpreted differently for the various encoder models (see EnDat Specifications) or EnDat additional data must be processed (e.g. incremental or battery-buffered encoders).

Interface	EnDat serial bidirectional
Data transfer	Position values, parameters and additional data
Data input	Differential line receiver according to EIA standard RS 485 for the signals $\overline{\text{CLOCK}}$, $\overline{\text{CLOCK}}$, DATA and $\overline{\text{DATA}}$
Data output	Differential line driver according to EIA standard RS 485 for DATA and $\overline{\text{DATA}}$ signals
Position values	Ascending during traverse in direction of arrow (see dimensions of the encoders)
Incremental signals	Depends on encoder $\sim 1 V_{PP}$ TTL, HTL (see the respective Incremental signals)

Order designations

The order designations define the central specifications and give information about:

- Typical power supply range
- Command set
- Availability of incremental signals
- Maximum clock frequency

The second character of the order designation identifies the interface generation. For encoders of the current generation the order designation can be read out from the encoder memory.

Incremental signals

Some encoders also provide incremental signals. These are usually used to increase the resolution of the position value, or to serve a second subsequent electronics unit. Current generations of encoders have a high internal resolution, and therefore no longer need to provide incremental signals. The order designation indicates whether an encoder outputs incremental signals:

- EnDat 01 With $1 V_{PP}$ incremental signals
- EnDat H With HTL incremental signals
- EnDat T With TTL incremental signals
- EnDat 21 Without incremental signals
- EnDat 02 With $1 V_{PP}$ incremental signals
- EnDat 22 Without incremental signals

Note on EnDat01/02:

The signal period is stored in the encoder memory

Voltage supply

The typical voltage supply of the encoders depends on the interface:

EnDat01 EnDat21	$5 V \pm 0.25 V$
EnDat02 EnDat22	3.6 V to 5.25 V or 14 V
EnDatH	10 V to 30 V
EnDatT	4.75 V to 30 V

Exceptions are documented in the Specifications.

Command set

The command set describes the available mode commands, which define the exchange of information between the encoder and the subsequent electronics. The EnDat 2.2 command set includes all EnDat 2.1 mode commands. In addition, EnDat 2.2 permits further mode commands for the selection of additional data, and makes memory accesses possible even in a closed control loop. When a mode command from the EnDat 2.2 command set is transmitted to an encoder that only supports the EnDat 2.1 command set, an error message is generated. The supported command set is stored in the encoder's memory area:

- EnDat01/21/H/T Command set 2.1 or 2.2
- EnDat02/22 Command set 2.2

For more information, refer to the *EnDat* Technical Information sheet or visit www.endat.de

Clock frequency

The clock frequency is variable—depending on the cable length (max. 150 m)—between 100 kHz and 2 MHz. With propagation-delay compensation in the subsequent electronics, either clock frequencies up to 16 MHz are possible or cable lengths up to 100 m. For EnDat encoders with order designation EnDat x2 the maximum clock frequency is stored in the encoder memory. For all other encoders the maximum clock frequency is 2 MHz. Propagation-delay compensation is provided only for order designations EnDat 21 and EnDat 22; for EnDat 02, see the notes below.

EnDat01 EnDatT EnDatH	≤ 2 MHz (see “without propagation-delay compensation” in the diagram)
EnDat21	≤ 2 MHz
EnDat02	≤ 2 MHz or ≤ 8 MHz or 16 MHz (see note)
EnDat22	≤ 8 MHz or 16 MHz

Transmission frequencies up to 16 MHz in combination with large cable lengths place high technological demands on the cable. Due to the data transfer technology, the adapter cable connected directly to the encoder must not be longer than 20 m. Greater cable lengths can be realized with an adapter cable no longer than 6 m and an extension cable. As a rule, the entire transmission path must be designed for the respective clock frequency.

Note on EnDat02

EnDat02 encoders can feature a pluggable cable assembly. In choosing the version of the adapter cable, the customer also decides whether the encoder will be operated with incremental signals or without them. This also affects the maximum possible clock frequency. For adapter cables with incremental signals the clock frequency is limited to at most 2 MHz; see EnDat 01. For adapter cables without incremental signals the clock frequency can be up to 16 MHz. The exact values are stored in the encoder’s memory.

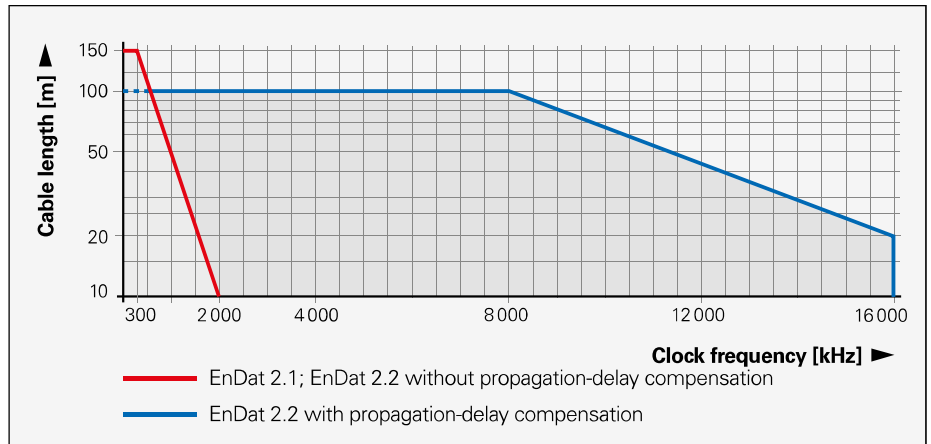

Under certain conditions, cable lengths up to 300 m are possible after consultation with HEIDENHAIN

Position values

The position value can be transmitted with or without additional data. It is not transmitted to the subsequent electronics until after the calculation time t_{cal} has passed. The calculation time is ascertained at the highest clock frequency permissible for the encoder, but at no greater than 8 MHz

Only the required number of bits is transferred for the position value. The bit number depends on the respective encoder and can be read out from the encoder for automatic parameterization.

Typical operating modes

Operating mode EnDat 2.1: This mode is for encoders that provide additional incremental signals. The absolute position is read out once simultaneously with the incremental position and both are used to calculate the position value. Otherwise, the position value in the control loop is formed on the basis of the incremental signals. Only EnDat 2.1 mode commands are used.

Operating mode EnDat 2.2: This mode is for purely serial encoders. The position value is read out from the encoder in each control cycle. EnDat 2.2 mode commands are typically used to read out the position value. EnDat 2.1 mode commands are typically used to read and write parameters after switch-on.

The EnDat 2.2 interface can interrogate the position and additional data, and also perform functions (e.g. read/write parameters, reset error messages, etc.), all within the closed loop.

Additional data

One or two items of additional data can be appended to the position value, depending on the type of transmission (selection via MRS code). The additional data supported by the respective encoder is saved in the encoder parameters.

The additional data contains:

Status information, addresses and data

- WRN – warnings
- RM – reference marks
- Busy – parameter request

Additional data 1

- Diagnosis
- Position value 2
- Memory parameters
- MRS-code acknowledgment
- Test values
- Temperature
- Additional sensors

Additional data 2

- Commutation
- Acceleration
- Limit position signals
- Asynchronous position value
- Operating status error sources
- Timestamp

Memory areas

The encoder provides several memory areas for parameters. These can be read from by the subsequent electronics, and some can be written to by the encoder manufacturer, the OEM, or even the end user. The parameter data are stored in a permanent memory. This memory permits only a limited number of write access events and is not designed for cyclic data storage. Certain memory areas can be write-protected (this can only be reset by the encoder manufacturer).

Parameters are saved in various memory areas, e.g.:

- Encoder-specific information
- Information of the OEM (e.g. "electronic ID label" of the motor)
- Operating parameters (datum shift, instruction, etc.)
- Operating status (alarm or warning messages)

Monitoring and diagnostic functions

of the EnDat interface make a detailed inspection of the encoder possible.

- Error messages
- Warnings
- Online diagnostics based on valuation numbers (EnDat 2.2)
- Mounting interface

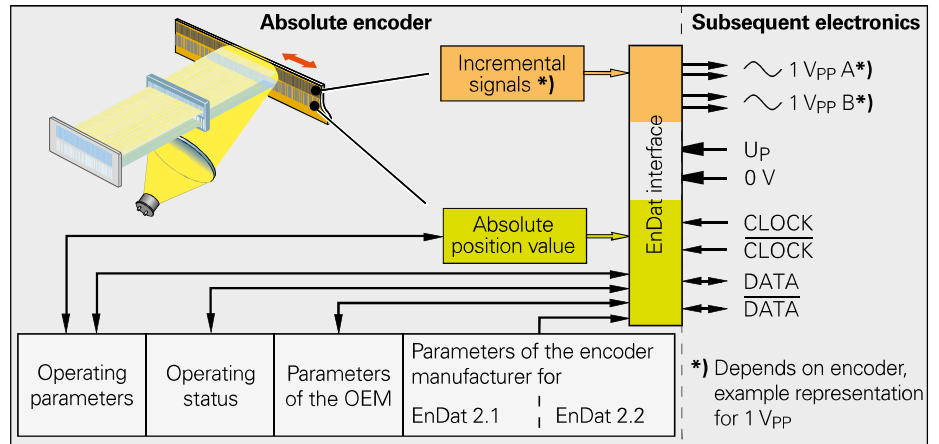

Functional safety – basic principle

EnDat 2.2 strictly supports the use of encoders in safety-related applications. The DIN EN ISO 13 849-1 (previously EN 954-1), EN 61 508 and EN 61 800-5-2 standards serve as the foundation. These standards describe the assessment of safety-oriented systems, for example based on the failure probabilities of integrated components and subsystems. The modular approach helps manufacturers of safety-related systems to implement their complete systems, because they can begin with prequalified subsystems.

Input circuitry of subsequent electronics

Dimensioning

IC_1 = RS 485 differential line receiver and driver

$$Z_0 = 120 \Omega$$

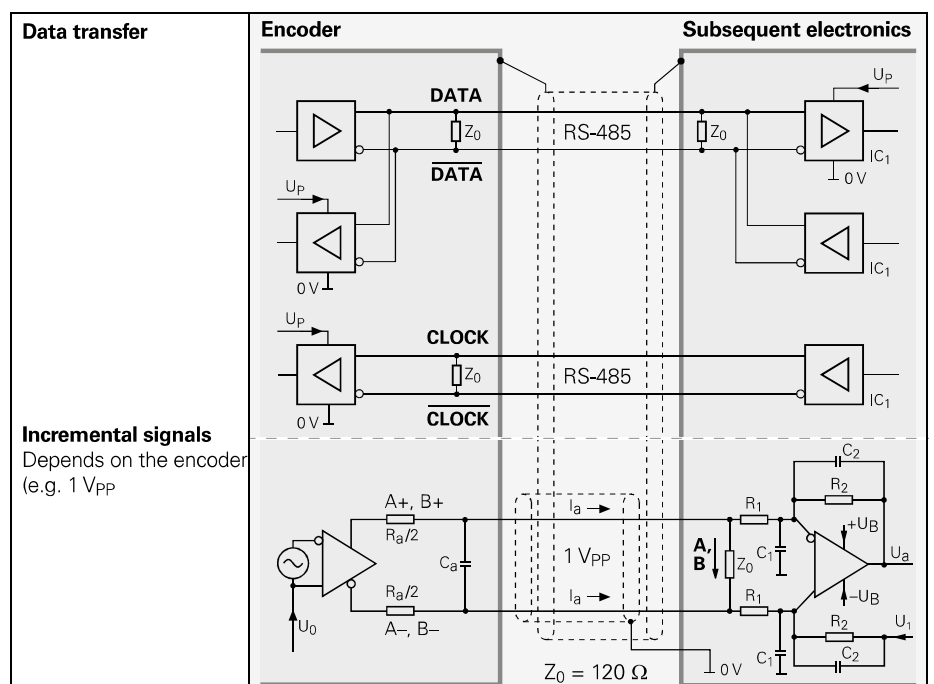

Company-specific serial interfaces

Siemens

HEIDENHAIN encoders with the code letter S after the model designation are suited for connection to Siemens controls with

- **DRIVE-CLiQ interface**
Order designation DQ01

Fanuc

HEIDENHAIN encoders with the code letter F after the model designation are suited for connection to Fanuc controls with

- **Fanuc Serial Interface – α Interface**
Ordering designation: Fanuc02
Normal and high speed, two-pair transmission
- **Fanuc Serial Interface – α i interface**
Ordering designation: Fanuc05
High speed, one-pair transmission
Includes α interface (normal and high speed, two-pair transmission)

Mitsubishi

HEIDENHAIN encoders with the code letter M after the model designation are suited for connection to Mitsubishi controls with

Mitsubishi high speed interface

- Ordering designation: Mitsu01
Two-pair transmission
- Ordering designation: Mit02-4
Generation 1, two-pair transmission
- Ordering designation: Mit02-2
Generation 1, one-pair transmission
- Ordering designation: Mit03-4
Generation 2, two-pair transmission

Yaskawa

HEIDENHAIN encoders with the code letter Y after the model designation are suited for connection to Yaskawa controls with

- **Yaskawa Serial Interface**
Ordering designation YEC02

Panasonic

HEIDENHAIN encoders with the code letter P after the model designation are suited for connection to Panasonic controls with

- **Panasonic Serial Interface**
Ordering designation Pana01

Position values

PROFIBUS-DP serial interface



PROFIBUS-DP

The PROFIBUS is a non-proprietary, open fieldbus according to the international standard EN 50170. The connecting of sensors through fieldbus systems minimizes the cost of cabling and reduces the number of lines between encoder and subsequent electronics.

Topology and bus assignment

The PROFIBUS-DP is designed as a linear structure. It permits transfer rates up to 12 Mbit/s. Both mono-master and multi-master systems are possible. Each master can serve only its own slaves (polling). The slaves are polled cyclically by the master. Slaves are, for example, sensors such as absolute rotary encoders, linear encoders, or also control devices such as motor frequency inverters.

Physical characteristics

The electrical features of the PROFIBUS-DP comply with the RS-485 standard. The bus connection is a shielded, twisted two-wire cable with active bus terminations at each end.

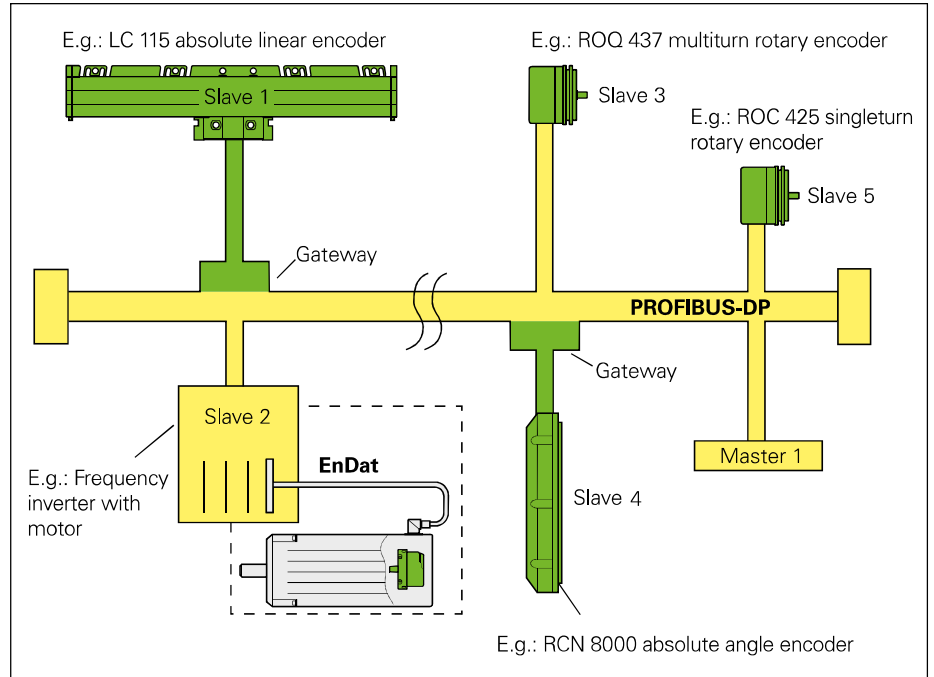

Bus structure of PROFIBUS-DP

Initial configuration

The characteristics of HEIDENHAIN encoders required for system configuration are included as “electronic data sheets”—also called device identification records (GSD)—in the gateway. These device identification records (GSD) completely and clearly describe the characteristics of a unit in an exactly defined format. This makes it possible to integrate the encoders into the bus system in a simple and application-friendly way.

Configuration

PROFIBUS-DP devices can be configured and the parameters assigned to fit the requirements of the user. Once these settings are made in the configuration tool with the aid of the GSD file, they are saved in the master. It then configures the PROFIBUS devices every time the network starts up. This simplifies exchanging of the devices: There is no need to edit or reenter the configuration data.

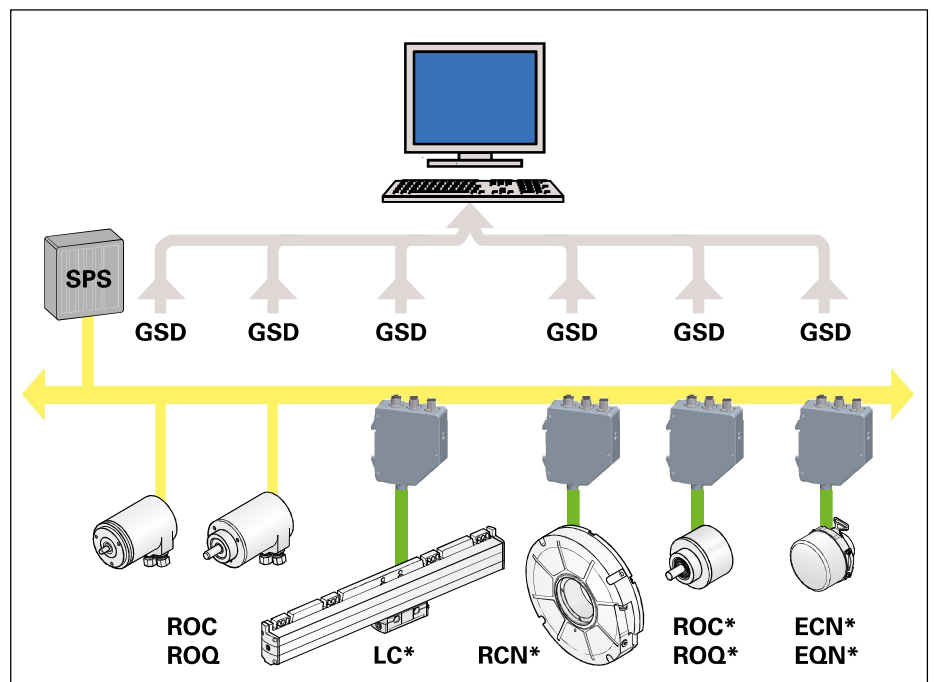

* With EnDat interface

Two different GSD files are available for selection:

- GSD file for the DP-V0 profile
- GSD file for the DP-V1 and DP-V2 profiles

PROFIBUS-DP profile

The PNO (PROFIBUS user organization) has defined standard, nonproprietary profiles for the connection of absolute encoders to the PROFIBUS-DP. This ensures high flexibility and simple configuration on all systems that use these standardized profiles.

DP-V0 profile

This profile can be obtained from the Profibus user organization (PNO) in Karlsruhe, Germany, under the order number 3.062. There are two classes defined in the profile, where class 1 provides minimum support, and class 2 allows additional, in part optional functions.

DP-V1 and DP-V2 profile

This profile can be obtained from the Profibus user organization (PNO) in Karlsruhe, Germany, under the order number 3.162. This profile also distinguishes between two device classes:

- Class 3 with the basic functions and
- Class 4 with the full range of scaling and preset functions.

Optional functions are defined in addition to the mandatory functions of classes 3 and 4.

Supported functions

Particularly important in decentralized field bus systems are the **diagnostic functions** (e.g. warnings and alarms), and the **electronic ID label** with information on the type of encoder, resolution, and measuring range. But programming functions such as counting direction reversal, **preset/zero shift** and **changing the resolution (scaling)** are also possible. The **operating time** and the velocity of the encoder can also be recorded.

Encoders with PROFIBUS-DP

Absolute encoders with **integrated PROFIBUS-DP interface** are connected directly to the PROFIBUS. LEDs on the rear of the encoder display the voltage supply and bus status **operating states**.

The coding switches for the addressing (0 to 99) and for selecting the terminating resistor are easily accessible under the bus housing. The terminating resistor is to be activated if the rotary encoder is the last participant on the PROFIBUS-DP and the external terminating resistor is not used.

Functions of the DP-V0 class

Dimension <i>Data word width</i>	Class	Rotational encoders		Linear encoders
		≤ 16 bits	≤ 31 bits ¹⁾	≤ 31 bits ¹⁾
Pos. value, pure binary code	1.2	✓	✓	✓
Data word length	1.2	16	32	32
Scaling function Measuring steps/rev Total resolution	2 2	✓ ✓	✓ ✓	– –
Reversal of counting direction	1.2	✓	✓	–
Preset (output data 16 or 32 bits)	2	✓	✓	✓
Diagnostic functions Warnings and alarms	2	✓	✓	✓
Operating time recording	2	✓	✓	✓
Velocity	2	✓ ²⁾	✓ ²⁾	–
Profile version	2	✓	✓	✓
Serial number	2	✓	✓	✓

¹⁾ With data word width > 31 bits, only the upper 31 bits are transferred

²⁾ Requires a 32-bit configuration of the output data and 32+16-bit configuration of the input data

Functions of the DP-V1, DP-V2 classes

Dimension <i>Data word width</i>	Class	Rotational encoders		Linear encoders
		≤ 32 bits	> 32 bits	
Telegram	3.4	81-84	84	81-84
Scaling function	4	✓	✓	–
Reversal of counting direction	4	✓	✓	–
Preset/Datum shift	4	✓	✓	✓
Acyclic parameters	3.4	✓	✓	✓
Channel-dependent diagnosis via alarm channel	3.4	✓	✓	✓
Operating time recording	3.4	✓ ¹⁾	✓ ¹⁾	✓ ¹⁾
Velocity	3.4	✓ ¹⁾	✓ ¹⁾	–
Profile version	3.4	✓	✓	✓
Serial number	3.4	✓	✓	✓

¹⁾ Not supported by DP V2

Position values

PROFINET IO serial interface



PROFINET IO

PROFINET IO is the open Industrial Ethernet Standard for industrial communication. It builds on the field-proven function model of PROFIBUS-DP, but uses fast Ethernet technology as physical transmission medium and is therefore tailored for fast transmission of I/O data. It offers the possibility of transmission for required data, parameters and IT functions at the same time.

PROFINET makes it possible to connect local field devices to a controller and describes the data exchange between the controller and the field devices, as well as the parameterization and diagnosis. The PROFINET technique is arranged in modules. Cascading functions can be selected by the user himself. These functions differ essentially in the type of data exchange in order to satisfy high requirements on velocity.

Topology and bus assignment

A PROFINET-IO system consists of:

- **IO controller** (control/PLC, controls the automation task)
- **IO device** (local field device, e.g. rotary encoder)
- **IO supervisor** (development or diagnostics tool, e.g. PC or programming device)

PROFINET IO functions according to the provider-consumer model, which supports communication between Ethernet peers. An advantage is that the provider transmits its data without any prompting by the communication partner.

Physical characteristics

HEIDENHAIN encoders are connected according to 100BASE-TX (IEEE 802.3 Clause 25) through one shielded, twisted wire pair per direction to PROFINET. The transmission rate is 100 Mbit/s (Fast Ethernet).

PROFINET profile

HEIDENHAIN encoders fulfill the definitions as per Profile 3.162, Version 4.1. The device profile describes the encoder functions. Class 4 (full scaling and preset) functions are supported. More detailed information on PROFINET can be ordered from the PROFIBUS user organization PNO.

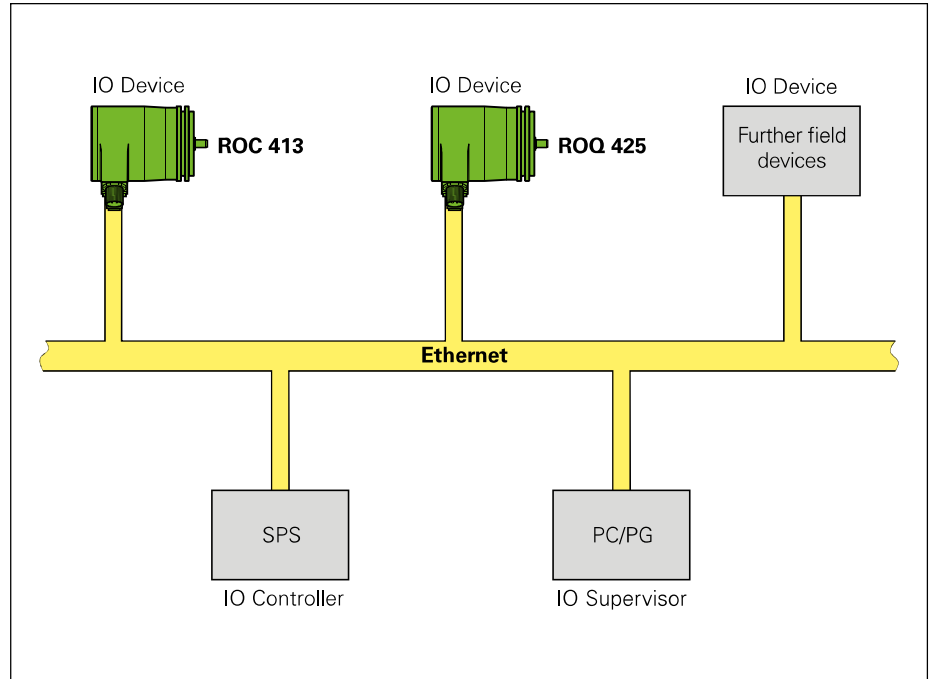

Supported functions	Class	Rotary encoders	
		Singletum	Multitum
Position value	3.4	✓	✓
Isochronous mode	3.4	✓	✓
Functionality of class 4	4	✓	✓
Scaling function	4	✓	✓
Measuring units per revolution	4	✓	✓
Total measuring range	4	✓	✓
Cyclic operation (binary scaling)	4	✓	✓
Noncyclic operation	4	✓	✓
Preset	4	✓	✓
Code sequence	4	✓	✓
Preset control G1_XIST1	4	✓	✓
Compatibility mode (encoder profile V.3.1)	3.4	✓	✓
Operating time	3.4	✓	✓
Velocity	3.4	✓	✓
Profile version	3.4	✓	✓
Permanent storage of the offset value	4	✓	✓
Identification & maintenance (I & M)		✓	✓
External firmware upgrade		✓	✓

Commissioning

To put an encoder with a PROFINET interface into operation, a device identification record (GSD) must be downloaded and imported into the configuration software. The GSD contains the execution parameters required for a PROFINET-IO device.

Configuration

Profiles are predefined configurations of available functions and performance characteristics of PROFINET for use in certain devices or applications such as rotary encoders. They are defined and published by the workgroups of PROFIBUS & PROFINET International (PI).

Profiles are important for openness, interoperability and exchangeability so that the end user can be sure that similar devices from different manufacturers function in a standardized manner.

Encoders with PROFINET

Absolute encoders with integrated PROFIBUS interface are connected directly to the network. Addresses are distributed automatically over a protocol integrated in PROFINET. A PROFINET-IO field device is addressed within a network through its physical device MAC address.

On their rear faces, the encoders feature two double-color LEDs for diagnostics of the bus and the device.

A terminating resistor for the last participant is not necessary.

Position values

SSI serial interface

The **absolute position value** beginning with the Most Significant Bit (MSB first) is transferred on the DATA lines in synchronism with a CLOCK signal transmitted by the control. The SSI standard data word length for singleturn encoders is 13 bits, and for multiturn encoders 25 bits. In addition to the absolute position values, **incremental signals** can be transmitted. See *Incremental signals* for a description of the signals.

For the ECN/EQN 4xx and ROC/ROQ 4xx rotary encoders, the following **functions** can be activated via the programming inputs of the interfaces by applying the supply voltage U_P :

- **Direction of rotation**
Continuous application of a HIGH level to PIN 2 ($t_{\min} > 1 \text{ ms}$) reverses the direction of rotation for ascending position values.
- **Zeroing** (datum setting)
Applying a positive edge ($t_{\min} > 12 \text{ ms}$) to PIN 5 sets the current position to zero.

Note: The programming inputs must always be terminated with a resistor (see "Input circuitry of the subsequent electronics").

Interface	SSI serial
Ordering designation	<i>Singleturn:</i> SSI 39r1 <i>Multiturn:</i> SSI 41r1
Data transfer	Absolute position values
Data input	Differential line receiver according to EIA standard RS 485 for the CLOCK and $\overline{\text{CLOCK}}$ signals
Data output	Differential line driver according to EIA standard RS 485 for DATA and $\overline{\text{DATA}}$ signals
Code	Gray code
Ascending position values	With clockwise rotation viewed from flange side (can be switched via interface)
Incremental signals	Depends on encoder $\sim 1 V_{PP}$ TTL, HTL (see the respective Incremental signals)
Programming inputs	Direction of rotation and zero reset (for ECN/EQN 4xx, ROC/ROQ 4xx)
Inactive Active	LOW $< 0.25 \times U_P$ HIGH $> 0.6 \times U_P$
Connecting cables	HEIDENHAIN cable with shielding e.g. PUR [(4 x 0.14 mm ²) + 4(2 x 0.14 mm ²) + (4 x 0.5 mm ²)] Max. 100 m at 90 pF/m distributed capacitance 6 ns/m
Cable length Propagation time	

Control cycle for complete data format

When not transmitting, the clock and data lines are on high level. The internally and cyclically formed position value is stored on the first falling edge of the clock. The stored data is then clocked out on the first rising edge.

After transmission of a complete data word, the data line remains low for a period of time (t_2) until the encoder is ready for interrogation of a new value. Encoders with the SSI 39r1 or SSI 41r1 interface additionally require a subsequent clock pause t_R .

If another data-output request (CLOCK) is received within this time (t_2 or t_2+t_R), the same data will be output once again.

If the data output is interrupted (CLOCK = High for $t \geq t_2$), a new position value will be stored on the next falling edge of the clock. With the next rising clock edge the subsequent electronics adopts the data.

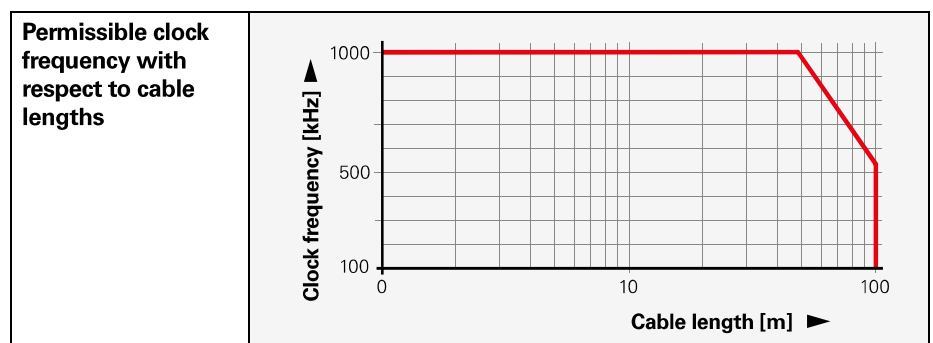
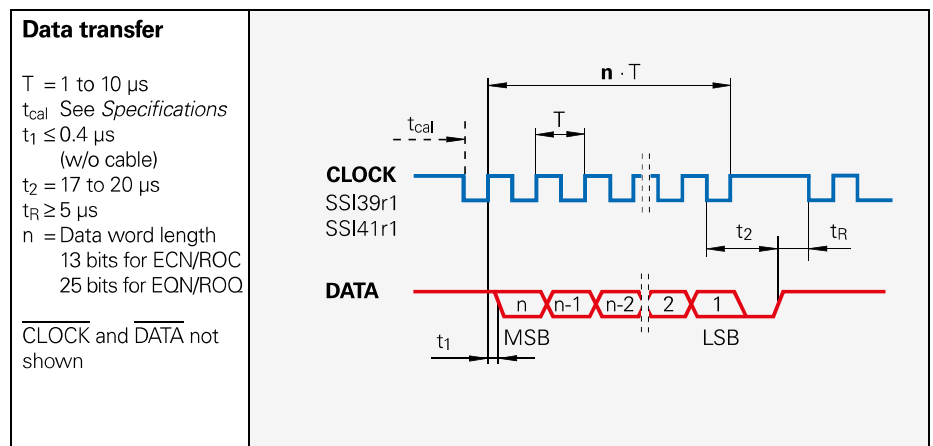

Incremental signals

Some encoders also provide incremental signals. These are usually used to increase the resolution of the position value, or to serve a second subsequent electronics unit. In general these are $1 V_{PP}$ incremental signals. Exceptions can be seen from the order designation:

- SSI41H With HTL incremental signals
- SSI41T With TTL incremental signals

Input circuitry of subsequent electronics

Dimensioning

IC_1 = Differential line receiver and driver
 E.g. SN 65 LBC 176
 LT 485

$Z_0 = 120 \Omega$

$C_3 = 330 \text{ pF}$ (serves to improve noise immunity)

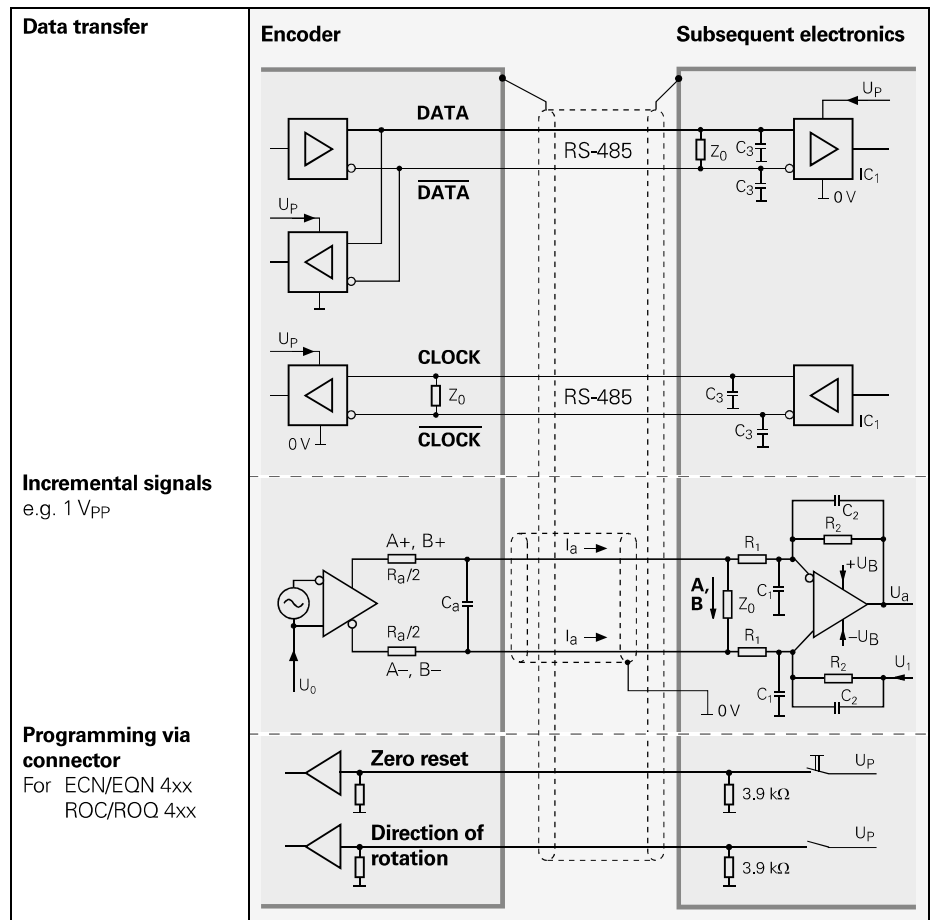

Other signals

Commutation signals for block commutation

The **block commutation signals U, V and W** are acquired from three separate tracks. They are transmitted as square-wave signals in TTL levels.

Interface	Square-wave signals \square TTL
Commutation signals	Three square-wave signals U, V, W and their inverse signals $\overline{U}, \overline{V}, \overline{W}$
Width	2x180° mech., 3x120° mech. or 4x90° mech. (other versions upon request)
Signal level	See <i>Incremental signals</i> \square TTL
Incremental signals	See <i>Incremental signals</i> \square TTL
Connecting cables	Shielded HEIDENHAIN cable e.g PUR [6(2 x 0.14 mm ²) + (4 x 0.5 mm ²)]
Cable length	Max. 100 m (492 ft)
Propagation time	6 ns/m

Commutation signals

(Values in mechanical degrees)

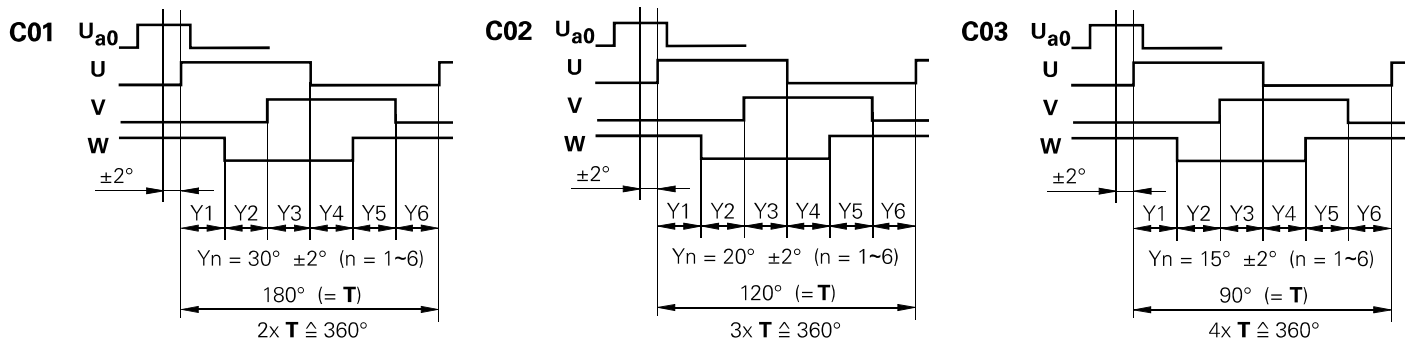

Commutation signals for sinusoidal commutation

The **commutation signals C and D** are taken from the Z1 track, and are equal to one sine or cosine period per revolution. They have a signal amplitude of typically $1 V_{PP}$ at $1 k\Omega$.

The input circuitry of the subsequent electronics is the same as for the $\sim 1 V_{PP}$ interface. The required terminating resistance Z_0 , however, is $1 k\Omega$ instead of 120Ω .

Interface	Sinusoidal voltage signals $\sim 1 V_{PP}$
Commutation signals	Two nearly sinusoidal signals C and D For the signal level, see <i>Incremental signals</i> $\sim 1 V_{PP}$
Incremental signals	See <i>Incremental signals</i> $\sim 1 V_{PP}$
Connecting cables	Shielded HEIDENHAIN cable z.B. PUR [4(2 x 0.14 mm ²) + (4 x 0.14 mm ²) + (4 x 0.5 mm ²)] Cable length Max. 150 m (492 ft) Propagation time 6 ns/m

Electronic commutation with Z1 track

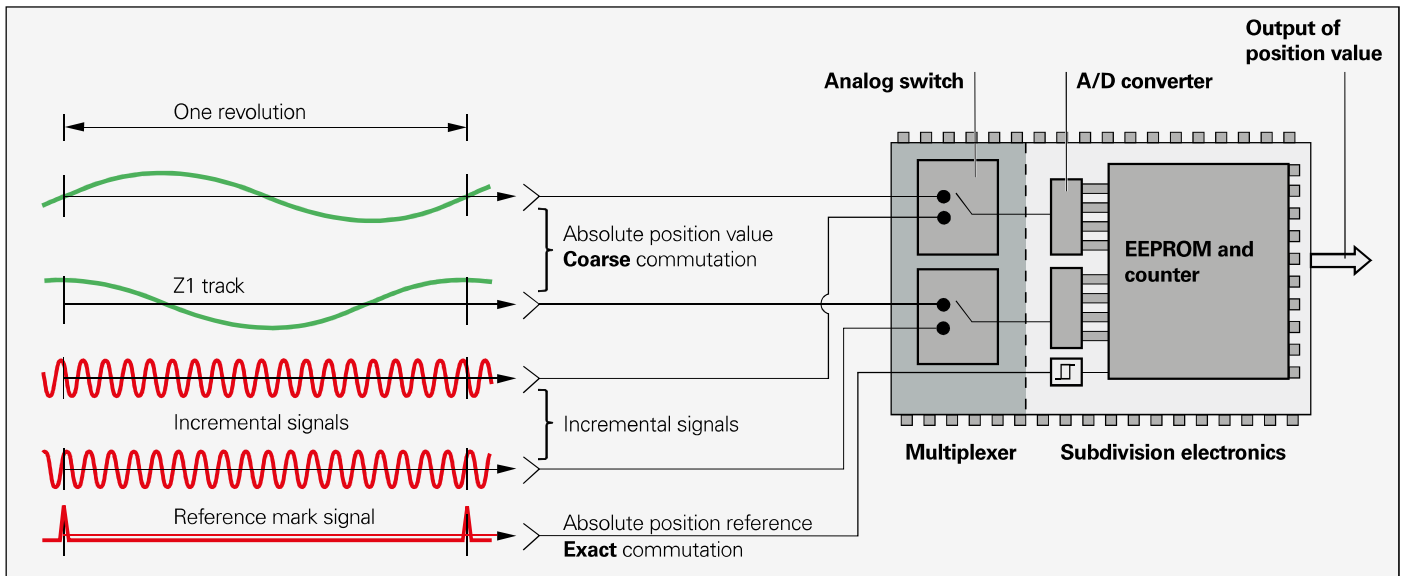

Other signals

Limit switches

Encoders with limit switches, such as LIDA 400, are equipped with two limit switches that make limit-position detection and the formation of homing tracks possible. The limit switches are activated by differing adhesive magnets to enable switching between the left or right limit. The magnets can be configured in series to form homing tracks.

The signals from the limit switches are sent over separate lines and are therefore directly available.

	LIDA 47x	LIDA 48x
Output signals	One TTL square-wave pulse from each limit switch L1 and L2; "active high"	
Signal amplitude	TTL from push-pull stage (e.g. 74 HCT 1G 08)	TTL from common-collector circuit with load resistance of 10 kΩ with respect to 5 V
Permissible load	$I_{aL} \leq 4 \text{ mA}$ $I_{aH} \leq 4 \text{ mA}$	
Switching times (10 % to 90 %)	Rise time Fall time	$t_+ \leq 50 \text{ ns}$ $t_- \leq 50 \text{ ns}$ Measured with 3 m cable and recommended input circuitry
		$t_+ \leq 10 \text{ } \mu\text{s}$ $t_- \leq 3 \text{ } \mu\text{s}$ Measured with 3 m cable and recommended input circuitry
Permissible cable length	Max. 20 m	

mm



Tolerancing ISO 8015
ISO 2768 - m H
< 6 mm: $\pm 0.2 \text{ mm}$

L1/L2 = Output signals of the limit switches 1 and 2
Tolerance of the switching point: $\pm 2 \text{ mm}$

- ⊙ = Beginning of measuring length (ML)
- ① = Magnet N for limit switch 1
- ② = Magnet S for limit switch 2

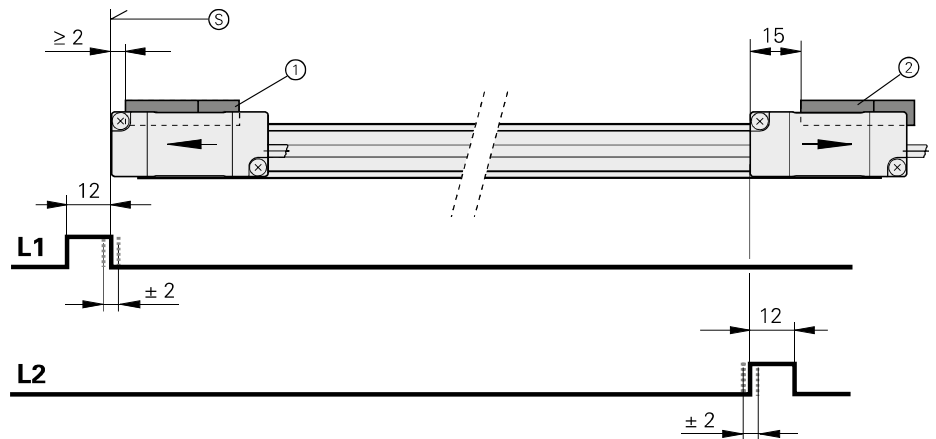

Input circuitry of subsequent electronics

Dimensioning

IC_3 e.g. 74AC14
 $R_3 = 1.5 \text{ k}\Omega$

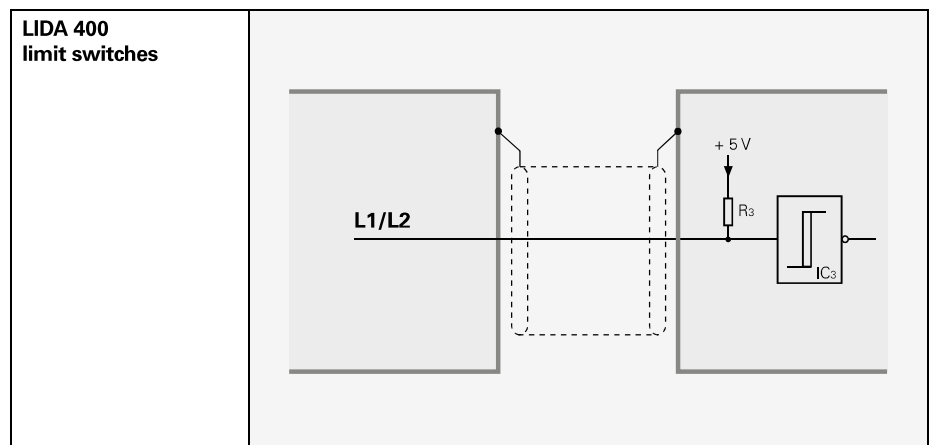

Position detection

In addition to the incremental graduation, encoders with position detection, such as the LIF 4x1, feature a homing track and limit switches for limit position detection.

The signals are transmitted in TTL levels over the separate lines H and L and are therefore directly available.

	LIF 4x1
Output signals	One TTL pulse each for homing track H and limit switch L
Signal amplitude	TTL $U_H \geq 3.8V$ with $-I_H = 8\text{ mA}$ $U_L \leq 0.45V$ with $I_L = 8\text{ mA}$
Permissible load	$R \geq 680\ \Omega$ $ I_L \leq 8\text{ mA}$
Permissible cable length	Max. 10 m

mm

 Tolerancing ISO 8015
 ISO 2768 - m H
 < 6 mm: $\pm 0.2\text{ mm}$

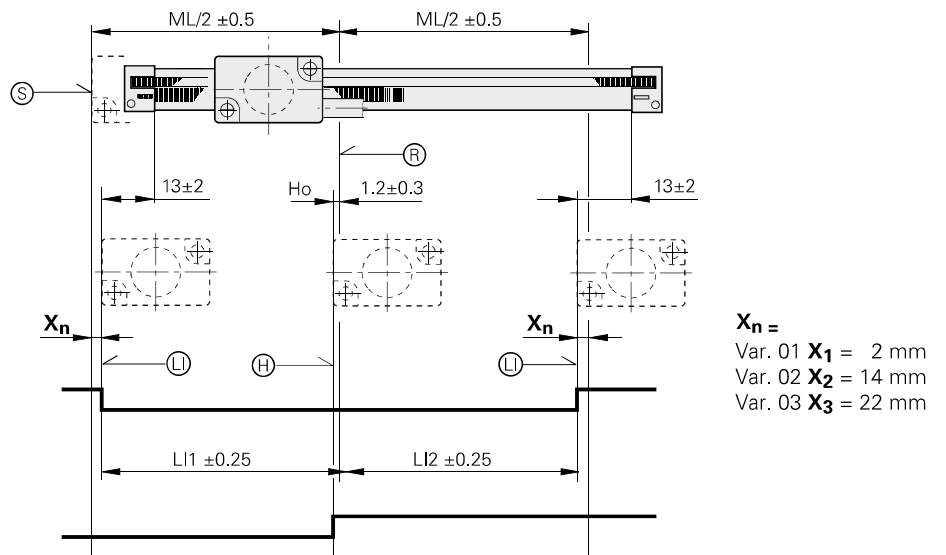
- ⊕ = Reference mark position
- Ⓢ = Beginning of measuring length (ML)
- Ⓛ = Limit mark, adjustable
- Ⓜ = Switch for homing track
- Ho = Trigger point for homing



Input circuitry of subsequent electronics

Dimensioning

IC₃ e.g. 74AC14
 R₃ = 4.7 k Ω

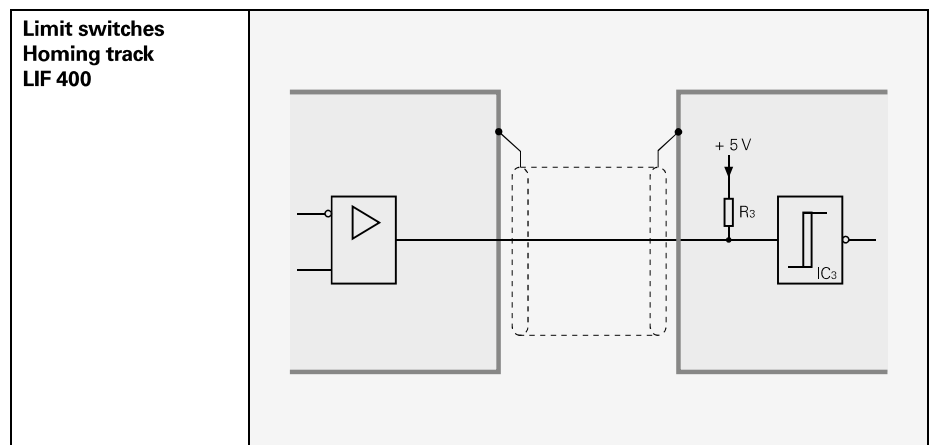

For more information

Interface electronics

Interface electronics from HEIDENHAIN adapt the encoder signals to the interface of the subsequent electronics. They are used when the subsequent electronics cannot directly process the output signals from HEIDENHAIN encoders, or if additional interpolation of the signals is necessary.

Input signals of the interface electronics

Interface electronics from HEIDENHAIN can be connected to encoders with sinusoidal signals of $1 V_{PP}$ (voltage signals) or $11 \mu A_{PP}$ (current signals). Encoders with the serial interfaces EnDat or SSI can also be connected to various interface electronics.

Output signals of the interface electronics

Interface electronics with the following interfaces to the subsequent electronics are available:

- TTL square-wave pulse trains
- EnDat 2.2
- DRIVE-CLiQ
- Fanuc Serial Interface
- Mitsubishi high speed interface
- Yaskawa Serial Interface
- Profibus

Interpolation of the sinusoidal input signals

In addition to being converted, the sinusoidal encoder signals are also interpolated in the interface electronics. This permits finer measuring steps and, as a result, higher control quality and better positioning behavior.

Formation of a position value

Some interface electronics have an integrated counting function. Starting from the last reference point set, an absolute position value is formed when the reference mark is traversed, and is transferred to the subsequent electronics.

Box design



Plug design



Version for integration



Top-hat rail design



Outputs		Inputs		Design – Protection class	Interpolation ¹⁾ or subdivision	Model	
Interface	Qty.	Interface	Qty.				
□TTL	1	~ 1 V _{PP}	1	Box design – IP 65	5/10-fold	IBV 101	
					20/25/50/100-fold	IBV 102	
					Without interpolation	IBV 600	
					25/50/100/200/400-fold	IBV 660B	
				Plug design – IP 40	5/10/20/25/50/100-fold	APE 371	
				Version for integration – IP 00	5/10-fold	IDP 181	
		20/25/50/100-fold	IDP 182				
		~ 11 μA _{PP}	1	Box design – IP 65	1	5/10-fold	EXE 101
						20/25/50/100-fold	EXE 102
						Without/5-fold	EXE 602E
25/50/100/200/400-fold	EXE 660B						
Version for integration – IP 00	5-fold	IDP 101					
	□TTL/ ~ 1 V _{PP} Adjustable	~ 1 V _{PP}	1	Box design – IP 65	2-fold	IBV 6072	
5/10-fold					IBV 6172		
5/10-fold and 20/25/50/100-fold					IBV 6272		
EnDat 2.2	1	~ 1 V _{PP}	1	Box design – IP 65	≤ 16384-fold subdivision	EIB 192	
				Plug design – IP 40	≤ 16384-fold subdivision	EIB 392	
			2	Box design – IP 65	≤ 16384-fold subdivision	EIB 1512	
DRIVE-CLiQ	1	EnDat 2.2	1	Box design – IP 65	–	EIB 2391S	
Fanuc Serial Interface	1	~ 1 V _{PP}	1	Box design – IP 65	≤ 16384-fold subdivision	EIB 192F	
				Plug design – IP 40	≤ 16384-fold subdivision	EIB 392F	
			2	Box design – IP 65	≤ 16384-fold subdivision	EIB 1592F	
Mitsubishi high speed interface	1	~ 1 V _{PP}	1	Box design – IP 65	≤ 16384-fold subdivision	EIB 192M	
				Plug design – IP 40	≤ 16384-fold subdivision	EIB 392M	
			2	Box design – IP 65	≤ 16384-fold subdivision	EIB 1592M	
Yaskawa Serial Interface	1	EnDat 2.2 ²⁾	1	Plug design – IP 40	–	EIB 3391Y	
PROFIBUS-DP	1	EnDat 2.1; EnDat 2.2	1	Top-hat rail design	–	PROFIBUS Gateway	

¹⁾ Switchable

²⁾ Only LIC 4100 with 5 nm measuring step, LIC 2100 with 50 nm and 100 nm measuring steps

Diagnostic and testing equipment

HEIDENHAIN encoders are provided with all information necessary for commissioning, monitoring and diagnostics. The type of available information depends on whether the encoder is incremental or absolute and which interface is used.

Incremental encoders mainly have 1 V_{PP} TTL or HTL interfaces. TTL and HTL encoders monitor their signal amplitudes internally and generate a simple fault detection signal. With 1 V_{PP} signals, the analysis of output signals is possible only in external test devices or through computation in the subsequent electronics (**analog diagnostics interface**).

Absolute encoders operate with serial data transfer. Depending on the interface, additional 1 V_{PP} incremental signals can be output. The signals are monitored comprehensively within the encoder. The monitoring result (especially with valuation numbers) can be transferred along with the position value through the serial interface to the subsequent electronics (**digital diagnostics interface**). The following information is available:

- Error message: Position value not reliable
- Warning: An internal functional limit of the encoder has been reached
- Valuation numbers:
 - Detailed information on the encoder's functional reserve
 - Identical scaling for all HEIDENHAIN encoders
 - Cyclic output is possible

This enables the subsequent electronics to evaluate the current status of the encoder at little cost even in closed-loop mode.

HEIDENHAIN offers the appropriate PWM inspection devices and PWT test devices for encoder analysis. There are two types of diagnostics, depending on how they are integrated:

- Encoder diagnostics: The encoder is connected directly to the test or inspection device. This makes a comprehensive analysis of encoder functions possible.
- Diagnostics in the control loop: The PWM phase meter is looped into the closed control loop (e.g. through a suitable testing adapter). This makes a real-time diagnosis of the machine or system possible during operation. The functions depend on the interface.

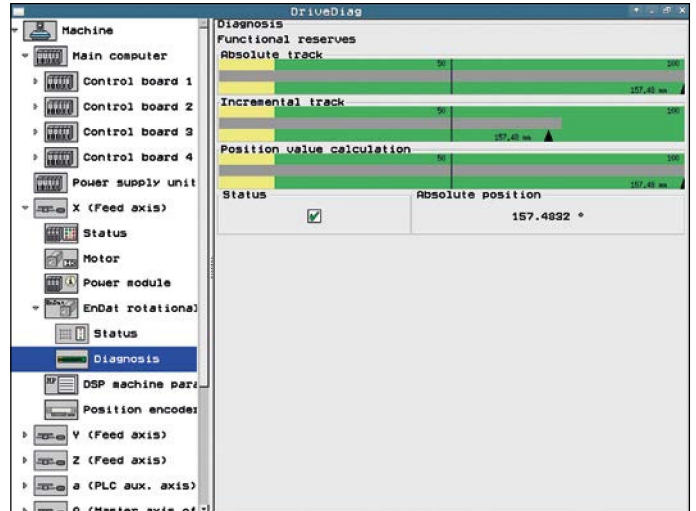

Diagnostics in the control loop on HEIDENHAIN controls with display of the valuation number or the analog encoder signals

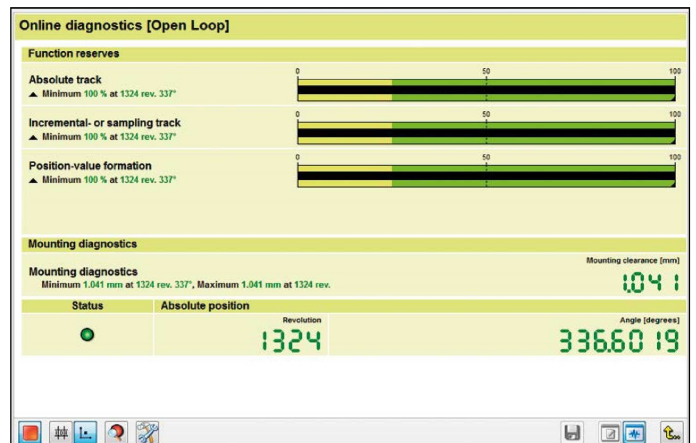

Diagnostics using PWM 20 and ATS software

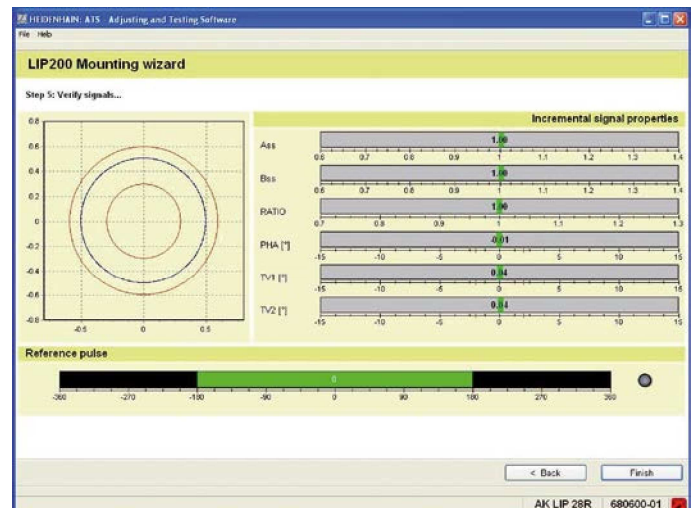

Commissioning using PWM 20 and ATS software

Overview		HEIDENHAIN testing equipment		
Interface	Output signals	PWM 20	PWM 9	PWT 1x ¹⁾
EnDat	Position value Incremental signals	Yes Yes	No Yes	No No
Fanuc	Position value	Yes	No	No
Mitsubishi	Position value	Yes	No	No
DRIVE-CLiQ	Position value	Yes	No	No
Yaskawa	Position value	Yes	No	No
SSI	Position value Incremental signals	Yes Yes	No Yes	No No
1 V _{PP}	Incremental signals	Yes	Yes	PWT 18
11 μA _{PP}	Incremental signals	Yes	Yes	PWT 10
TTL	Incremental signals	Yes	Yes	PWT 17
HTL	Incremental signals	Yes ²⁾	Yes	No
Commutation	Block commutation Sinusoidal commutation	Being planned Yes	Yes Yes	No No

¹⁾ The PWT is an aid for setting and adjustment

²⁾ Over signal adapter

The **PWM 9** is a universal measuring device for checking and adjusting HEIDENHAIN incremental encoders. Expansion modules are available for checking the various types of encoder signals. The values can be read on an LCD monitor. Soft keys provide ease of operation.



PWM 9	
Inputs	Expansion modules (interface boards) for 11 μA _{PP} ; 1 V _{PP} ; TTL; HTL; EnDat*/SSI*/commutation signals *No display of position values or parameters
Functions	<ul style="list-style-type: none"> • Measures signal amplitudes, current consumption, operating voltage, output frequency • Graphically displays incremental signals (amplitudes, phase angle and on-off ratio) and the reference-mark signal (width and position) • Displays symbols for the reference mark, fault-detection signal, counting direction • Universal counter, interpolation selectable from single to 1024-fold • Adjustment support for exposed linear encoders
Outputs	<ul style="list-style-type: none"> • Inputs are connected through to the subsequent electronics • BNC sockets for connection to an oscilloscope
Voltage supply	10 V to 30 V DC, max. 15 W
Dimensions	150 mm × 205 mm × 96 mm

The **PWT** is a simple adjusting aid for HEIDENHAIN incremental encoders. In a small LCD window, the signals are shown as bar charts with reference to their tolerance limits.



	PWT 10	PWT 17	PWT 18
Encoder input	~ 11 μ A _{PP}	□TTL	~ 1 V _{PP}
Functions	Measurement of signal amplitude Wave-form tolerance Amplitude and position of the reference mark signal		
Voltage supply	Via power supply unit (included)		
Dimensions	114 mm x 64 mm x 29 mm		

PWM 20

The PWM 20 phase angle measuring unit serves together with the provided ATS adjusting and testing software for diagnosis and adjustment of HEIDENHAIN encoders.



	PWM 20
Encoder input	<ul style="list-style-type: none"> • EnDat 2.1 or EnDat 2.2 (absolute value with/without incremental signals) • DRIVE-CLiQ • Fanuc Serial Interface • Mitsubishi high speed interface • Yaskawa Serial Interface • SSI • 1 V_{PP}/TTL/11 μA_{PP}
Interface	USB 2.0
Voltage supply	100 V to 240 V AC or 24 V DC
Dimensions	258 mm x 154 mm x 55 mm

	ATS
Languages	Choice between English and German
Functions	<ul style="list-style-type: none"> • Position display • Connection dialog • Diagnostics • Mounting wizard for EBI/ECI/EQI, LIP 200, LIC 4000 and others • Additional functions (if supported by the encoder) • Memory contents
System requirements and recommendations	PC (dual-core processor, > 2 GHz) RAM > 2 GB Windows operating systems XP, Vista, 7 (32-bit/64-bit), 8 200 MB free space on hard disk

DRIVE-CLiQ is a registered trademark of Siemens Aktiengesellschaft

The **APS 27** encoder diagnostic kit is necessary for assessing the mounting tolerances of the LIDA 27x with TTL interface. To examine them, the LIDA 27x is either connected to the subsequent electronics via the PS 27 test connector, or is operated directly on the PG 27 test unit.

Green LEDs for the incremental signals and reference pulse, respectively, indicate correct mounting. If they shine red, then the mounting must be checked again.



	APS 27
Encoder	LIDA 277/LIDA 279
Function	Good/bad detection of the TTL signals (incremental signals and reference pulse)
Voltage supply	Via subsequent electronics or power supply unit (included in delivery)
Items supplied	PS 27 test connector PG 27 test unit Power supply unit for PG 27 (110 V to 240 V, including adapter plug) Shading films

The **SA 27** adapter connector serves for tapping the sinusoidal scanning signals of the LIP 372 off the APE. Exposed pins permit connection to an oscilloscope through standard measuring cables.

	SA 27
Encoder	LIP 372
Function	Measuring points for the connection of an oscilloscope
Voltage supply	Via encoder
Dimensions	≈ 30 mm x 30 mm

General electrical information

Scope

The general electrical information applies to encoders from HEIDENHAIN. Deviations are indicated in the *Specifications*.

Voltage supply

Connect HEIDENHAIN encoders only to subsequent electronics whose power supply is generated from PELV systems (EN 50 178).

HEIDENHAIN encoders fulfill the requirements of standard IEC 61010-1 only if the power is supplied from a secondary circuit with current limitation as per IEC 61010^{3rd Ed.}, Section 9.4 or with power limitation as per IEC 60950-1^{2nd Ed.}, Section 2.5 or from a Class 2 secondary circuit as specified in UL1310.¹⁾

The encoders require a **stabilized DC voltage U_P** as voltage supply. The required current consumption and power consumption are listed in the respective *Specifications*. The permissible ripple content of the DC voltage is:

- High frequency interference
 $U_{PP} < 250 \text{ mV}$ with $dU/dt > 5 \text{ V}/\mu\text{s}$
- Low frequency fundamental ripple
 $U_{PP} < 100 \text{ mV}$

However, the limits of the supply voltage must not be violated by the ripple content.

The values apply as measured at the encoder. The voltage can be monitored and adjusted with the encoder's **sensor lines**, if available. If an adjustable power supply is not available, the voltage drop can be reduced by switching the sensor lines parallel to the corresponding supply wires.

The voltage U_P actually applied to the encoder is to be considered when **calculating the encoder's current and power consumption**. This voltage consists of the supply voltage U_E provided by the subsequent electronics minus the **voltage drop ΔU** in the supply wires.

For **encoders with an expanded supply voltage range**, the calculation of the voltage drop ΔU in the supply wires must consider the nonlinear current consumption (see below).

For **encoders without expanded supply voltage range** (typical supply voltage 5 V) the voltage drop ΔU in the supply wires is calculated as follows:

$$\Delta U = 2 \cdot \frac{1.05 \cdot L_C}{56 \cdot A_P} \cdot I_M \cdot 10^{-3}$$

Where:

ΔU	Line drop in V
L_C	Cable length in m
A_P	Cross section of supply wires in mm^2 (see cable)
I_M	Current consumption in mA
2	Outgoing and incoming lines
1.05	Length factor due to twisted wires
56	Electrical conductivity of copper

If the value for the voltage drop is known, the parameters of voltage at the encoder, current consumption, as well as power consumption of the encoder and the power provided by the subsequent electronics can be calculated for the encoder and subsequent electronics.

Switch-on/off behavior of the encoders

After the switch-on time t_{SOT} , valid output signals are available. During the time t_{SOT} , the output signals reach the maximum voltage values given in the table. The switch-on time t_{SOT} depends on the interface.

Interface	Switch-on time t_{SOT}	Maximum voltage
1 V _{PP}	1.3 s	5.5 V
11 μA_{PP}		
TTL		
HTL	2 s	U_{Pmax}
EnDat		5.5 V
SSI	10 s	U_{Pmax}
PROFIBUS-DP		5.5 V
PROFINET		U_{Pmax}

If the power supply is switched off, or when the supply voltage falls below U_{Pmin} , the output signals are also invalid.

Furthermore, the interface-specific switch-on/off characteristics must be considered. If interface electronics are inserted between the encoder and the subsequent electronics, the switch-on/off characteristics of the interface electronics must also be considered.

During restart, the voltage must remain below 0.2 V for the time t_{SOT} before power on. Other proprietary interfaces supported by HEIDENHAIN are not considered.

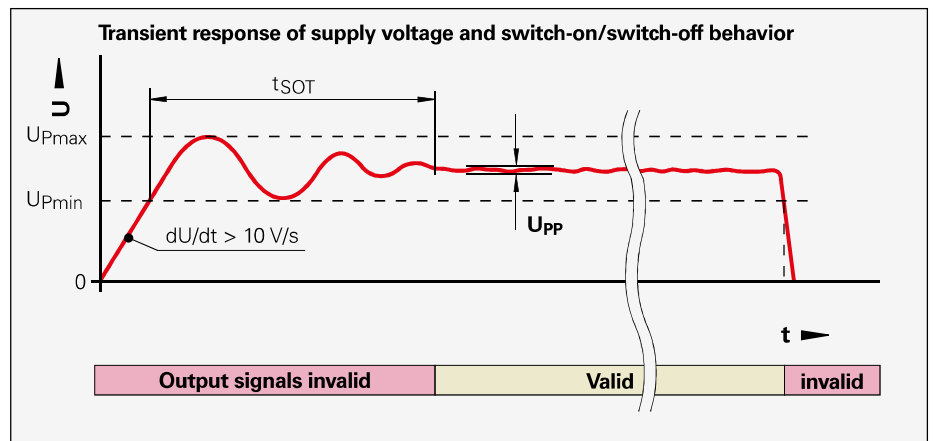

¹⁾ In place of IEC 61010-1^{3rd Ed.}, Section 9.4, the corresponding sections of standards DIN EN 61010-1, EN61010-1, UL 61010-1 and CAN/CSA-C22.2 No. 61010-1 can be applied and in place of IEC 60950-1^{2nd Ed.}, Section 2.5 the corresponding sections of standards DIN EN60950-1, EN60950-1, UL60950-1, CAN/CSA-C22.2 No. 60950-1 can be applied.

Encoders with expanded supply voltage range

For encoders with expanded supply voltage range, the current consumption has a nonlinear relationship with the supply voltage. On the other hand, the power consumption follows an approximately linear curve (see *Current and power consumption diagram*).

The maximum power consumption at minimum and maximum supply voltage is listed in the **Specifications**. The maximum power consumption accounts for:

- Recommended receiver circuit
- Cable length: 1 m
- Aging and influences of temperature
- Proper use of the encoder with respect to clock frequency and cycle time

For comparative and inspection purposes, the typical current or power consumption is additionally listed in typical ambient and operating conditions without load (only voltage supply connected) for the typical supply voltage or rated voltage.

This information only has informative character; it is subject to change without notice. The maximum power consumption is to be used for dimensioning the voltage supply.

Influence of cable length on the power output of the subsequent electronics (example representation)

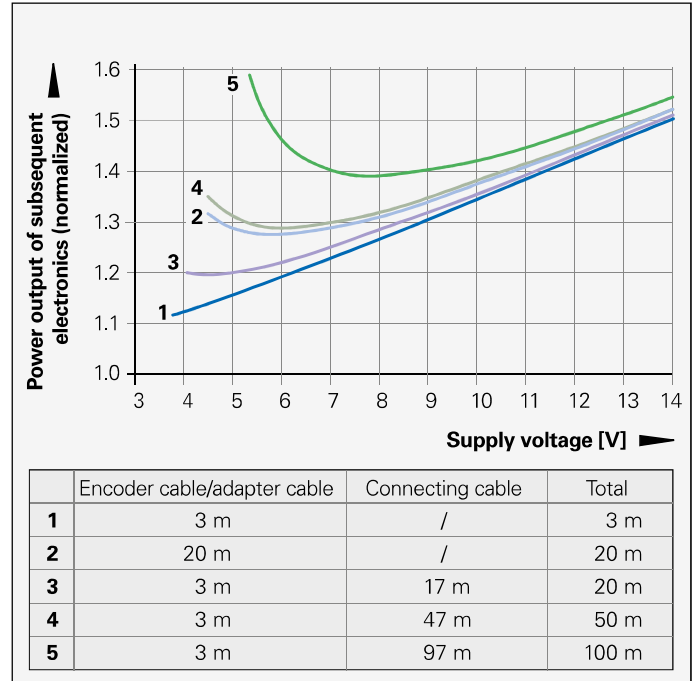

Current and power consumption with respect to the supply voltage (example representation)

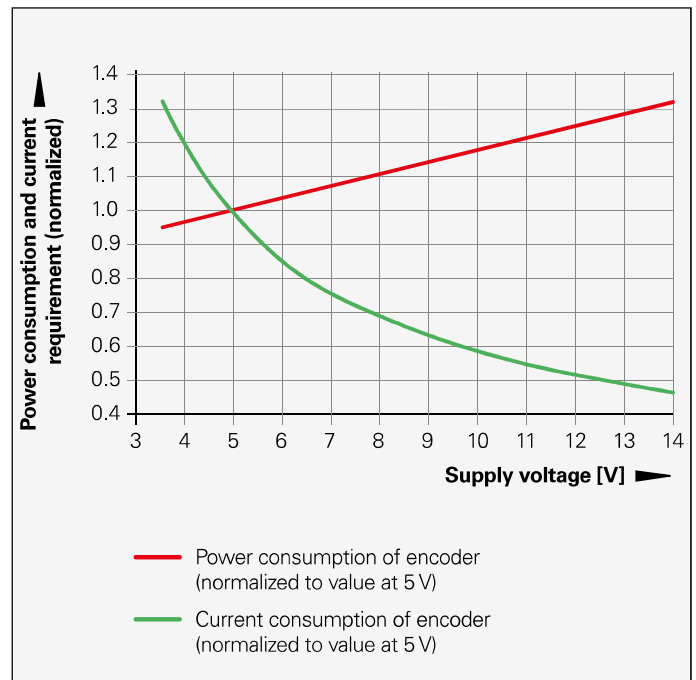

The **actual power consumption** of the encoder and the required power output of the subsequent electronics are calculated, while taking the voltage drop on the supply wires into consideration, in four steps:

Step 1: Resistance of the supply wires

The resistance values of the supply wires (adapter cable and encoder cable) can be calculated with the following formula:

$$R_L = 2 \cdot \frac{1.05 \cdot L_C}{56 \cdot A_P}$$

Step 2: Coefficients for calculation of the drop in line voltage

$$b = -R_L \cdot \frac{P_{Mmax} - P_{Mmin}}{U_{Pmax} - U_{Pmin}} - U_E$$

$$c = P_{Mmin} \cdot R_L + \frac{P_{Mmax} - P_{Mmin}}{U_{Pmax} - U_{Pmin}} \cdot R_L \cdot (U_E - U_{Pmin})$$

Step 3: Voltage drop based on the coefficients b and c

$$\Delta U = -0.5 \cdot (b + \sqrt{b^2 - 4 \cdot c})$$

Step 4: Parameters for subsequent electronics and the encoder

Voltage at encoder:

$$U_P = U_E - \Delta U$$

Current requirement of encoder:

$$I_M = \frac{\Delta U}{R_L}$$

Power consumption of encoder:

$$P_M = U_P \cdot I_M$$

Power output of subsequent electronics:

$$P_E = U_E \cdot I_M$$

Where:

- R_L Resistance of supply wires (for both directions) in ohms
- L_C Cable length in m
- A_P Cross section of supply wires in mm^2 (see cable)
- 2 Outgoing and incoming lines
- 1.05 Length factor due to twisted wires
- 56 Electrical conductivity of copper
- P_{Mmin}, P_{Mmax} Maximum power consumption at minimum and maximum power supply voltage, respectively, in W
- U_{Pmin}, U_{Pmax} Minimum or maximum supply voltage of the encoder in V
- U_E Supply voltage at the subsequent electronics in V
- ΔU Voltage drop in the cable in V
- U_P Voltage at encoder in V
- I_M Current requirement of encoder in mA
- P_M Power consumption of encoder in W
- P_E Power output of subsequent electronics in W

If an encoder operates with the subsequent electronics via **interface electronics**, the power consumption of the encoder and of the interface electronics must be added to calculate the resulting power consumption.

Depending on the interface electronics, a compensation factor for the efficiency of the interface electronics' switching power supply (see Product Information) may have to be considered.

Encoders with **DRIVE-CLiQ interface** are designed for a rated voltage of 24 V DC. The subsequent electronics manufacturer specifies 20.4 V to 28.8 V DC as the tolerance of the voltage supply.

HEIDENHAIN encoders with DRIVE-CLiQ interface permit a greater voltage range (see Specifications). Operation is briefly allowed up to 36.0 V DC. Higher power consumption is to be expected in the range of 28.8 V to 36.0 V DC.

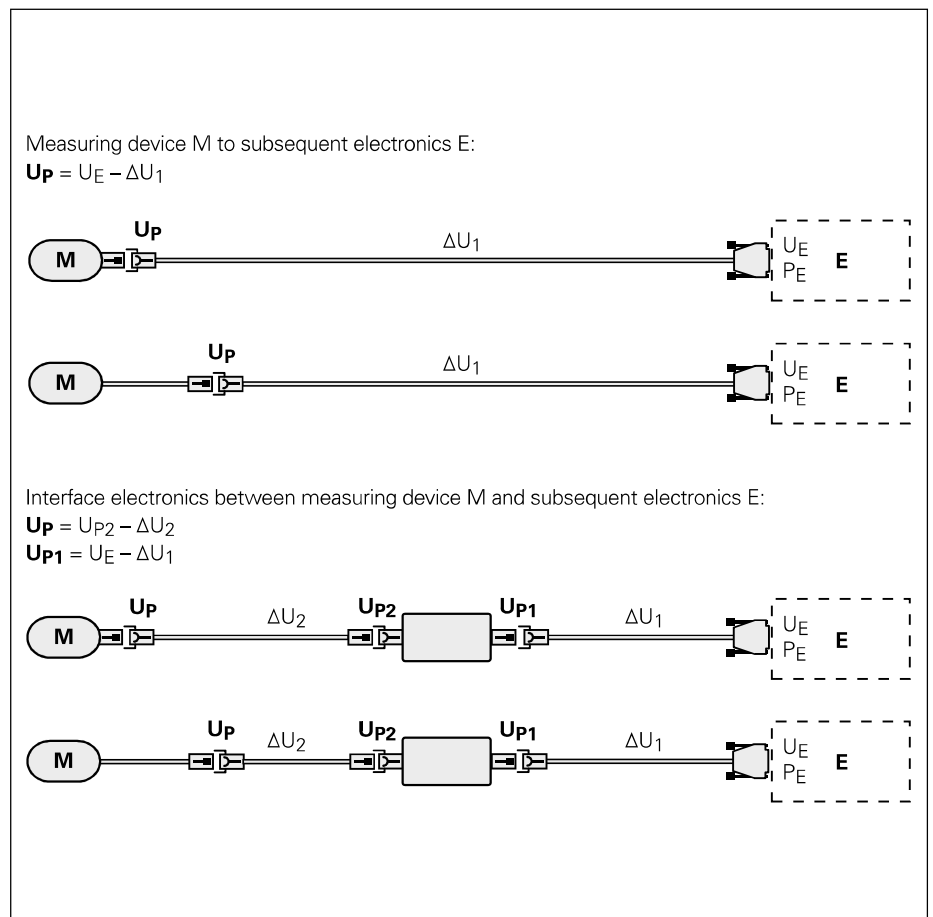

Calculation example

This specific example is used to determine the relevant parameters for operating an encoder:

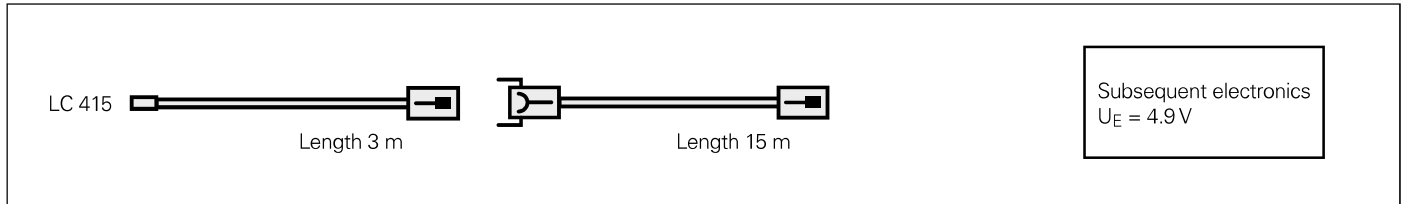

Encoder used

LC 415

- Supply voltage is 3.6 V to 14 V DC (from *Specifications*)
- Power consumption at 14 V: ≤ 1.5 W; at 3.6 V: ≤ 1.1 W (from *Specifications*)

Cables used

Adapter cable (L1)

- Length $L_{C1} = 3$ m
- Cable diameter 4.5 mm
- $A_P = 0.14$ mm² (from *Connecting elements and cables*)

Connecting cable (L2)

- Length $L_{C2} = 15$ m
- Cable diameter 4.5 mm
- $A_P = 0.34$ mm² (from *Connecting elements and cables*)

Constraints from subsequent electronics

- **Sensor lines** are used additionally for the power supply, doubling the cross-section
- **Supply voltage** of the subsequent electronics $U_E = 4.9$ V

Step 1: Resistance of the supply wires

$$R = 2 \times (1.05 \times L_K) / (56 \times 2A_P)$$

$$R_{L1} = 0.402 \, \Omega$$

$$R_{L2} = 0.827 \, \Omega$$

$$R_L = 1.229 \, \Omega$$

Step 2: Coefficients for calculation of the voltage drop

$$b = -R_L \cdot \frac{P_{Mmax} - P_{Mmin}}{U_{Pmax} - U_{Pmin}} - U_E$$

$$b = -1.229 \times (1.5 - 1.1) / (14 - 3.6) - 4.9$$

$$b = -4.947$$

$$c = P_{Mmin} \cdot R_L + \frac{P_{Mmax} - P_{Mmin}}{U_{Pmax} - U_{Pmin}} \cdot R_L \cdot (U_E - U_{Pmin})$$

$$c = 1.1 \times 1.229 + (1.5 - 1.1) / (14 - 3.6) \times 1.229 \times (4.9 - 3.6)$$

$$c = 1.413$$

Step 3: Voltage drop based on the coefficients b and c

$$\Delta U = -0.5 \cdot (b + \sqrt{b^2 - 4 \cdot c})$$

$$\Delta U = -0.5 \times [-4.947 + \sqrt{(-4.947)^2 - 4 \times 1.413}]$$

$$\Delta U = 0.304 \, \text{V}$$

Step 4: Parameters for subsequent electronics and the encoder

Voltage at encoder

$$U_P = U_E - \Delta U$$

$$U_P = 4.9 \, \text{V} - 0.304 \, \text{V}$$

$$U_P = 4.596 \, \text{V}$$

Voltage at encoder is greater than 3.6 V, and is therefore within the permissible range

Current requirement of the encoder

$$I_M = \Delta U / R_L$$

$$I_M = 0.304 \, \text{V} / 1.229 \, \Omega$$

$$I_M = 248 \, \text{mA}$$

Power consumption of encoder

$$P_M = U_P \times I_M$$

$$P_M = 4.596 \, \text{V} \times 248 \, \text{mA}$$

$$P_M = 1138 \, \text{mW}$$

Power output of subsequent electronics

$$P_E = U_E \times I_M$$

$$P_E = 4.9 \, \text{V} \times 248 \, \text{mA}$$

$$P_E = 1214 \, \text{mW}$$

Electrically permissible speed/ traversing velocity

The maximum permissible shaft speed or traversing velocity of an encoder is derived from

- the **mechanically** permissible shaft speed or traversing velocity and
- the **electrically** permissible shaft speed or traversing velocity.

For incremental encoders with **sinusoidal output signals**, the electrically permissible shaft speed or traversing velocity is limited by the $-3\text{dB}/-6\text{dB}$ cutoff frequency or the permissible input frequency of the subsequent electronics.

For incremental encoders with **square-wave signals**, the electrically permissible shaft speed or traversing velocity is limited by

- the maximum permissible scanning frequency f_{max} of the encoder and
- the minimum permissible edge separation a for the subsequent electronics.

For angle or rotary encoders

$$n_{\text{max}} = \frac{f_{\text{max}}}{z} \cdot 60 \cdot 10^3$$

For linear encoders

$$v_{\text{max}} = f_{\text{max}} \cdot \text{SP} \cdot 60 \cdot 10^{-3}$$

Where:

n_{max}	Electrically permissible speed in min^{-1}
v_{max}	Electrically permissible traversing velocity in m/min
f_{max}	Maximum scanning/output frequency of encoder or input frequency of subsequent electronics in kHz
z	Signal periods of the angle or rotary encoder per 360°
SP	Signal period of the linear encoder in μm

Cables

Versions

The cables of almost all HEIDENHAIN encoders as well as adapter and connecting cables are sheathed in **polyurethane (PUR)**. In addition, **special elastomer (EPG)**, **special thermoplastic elastomer (TPE)** and **polyvinyl chloride (PVC)** are used.

These cables are identified in the catalog as PUR, EPG, TPE or PVC.

Durability

PUR cables are resistant to oil and hydrolysis and microbes in accordance with EN 60811-2-1 and resistant to microbes in accordance EN 50363-10-2. They are free of PVC and silicone and comply with UL safety directives. The **UL certification** AWM STYLE 20963 80 °C 30 V E63216 is documented on the cable.

EPG cables are suitable for high temperatures and are resistant to oil in accordance with EN 60811-2-1, hydrolysis in accordance with EN 50363-10-2, and are free of PVC, silicone and halogens. In comparison with PUR cables, they are only somewhat resistant to media, frequent flexing and continuous torsion.

PVC cables are oil-resistant. The UL certification is documented on the cable with AWM E64638 STYLE20789 105C VW-1SC NIKKO.

TPE wires with braided sleeving are slightly oil resistant.

Cable	Material	Bend radius R	
		Rigid configuration	Frequent flexing
Ø 3.7 mm	PUR	≥ 8 mm	≥ 40 mm
Ø 4.3 mm		≥ 10 mm	≥ 50 mm
Ø 4.5 mm			
Ø 4.5 mm	EPG	≥ 18 mm	–
Ø 5.1 mm	PUR	≥ 10 mm	≥ 50 mm
Ø 5.5 mm	PVC	Upon request	Upon request
Ø 6 mm	PUR	≥ 20 mm	≥ 75 mm
Ø 6.8 mm			
Ø 8 mm		≥ 40 mm	≥ 100 mm
Ø 10 mm ¹⁾		≥ 35 mm	≥ 75 mm
Ø 14 mm ¹⁾		≥ 100 mm	≥ 100 mm
TPE wires with braided sleeving		TPE	≥ 10 mm

¹⁾ Metal armor

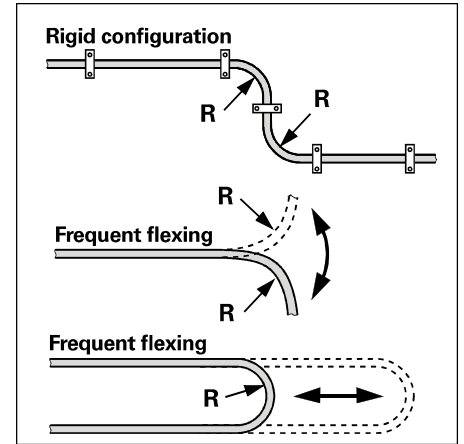

Temperature range

	Rigid configuration	Frequent flexing
PUR	-40 °C to 80 °C	-10 °C to 80 °C
EPG	-40 °C to 120 °C	–
TPE	-40 °C to 120 °C	–
PVC	-20 °C to 90 °C	-10 °C to 90 °C

With limited hydrolytic and media exposure, some PUR cables can be used at temperatures up to 100 °C. If needed, please ask for assistance from HEIDENHAIN.

Lengths

The **cable lengths** listed in the *Specifications* apply only for HEIDENHAIN cables and the recommended input circuitry of subsequent electronics.

Attainable cable lengths for absolute linear and angle encoders

In practice, the interfaces for HEIDENHAIN linear encoders permit long cables, sometimes even up to 150 m. However, long cable lengths also result in a large voltage drop on the supply lines. The magnitude of this depends on the wire cross-section of the supply lines, along with the usual criteria of the cable length and the current required by the encoder.

Particularly for long cables and encoders with a high current consumption (mainly absolute linear and angle encoders), the voltage drop can lead to the encoder's supply voltage falling below the minimum permissible level. Possible remedies:

- For long lengths, select cables with large wire cross-sections
- Keep thin cables, with small wire cross-sections, as short as possible
- For subsequent electronics without controllable power supply unit, connect the sensor lines parallel to the supply lines. This doubles the available cross-section.
- Select as high a supply voltage U_P as possible, e.g. 5.25 V DC

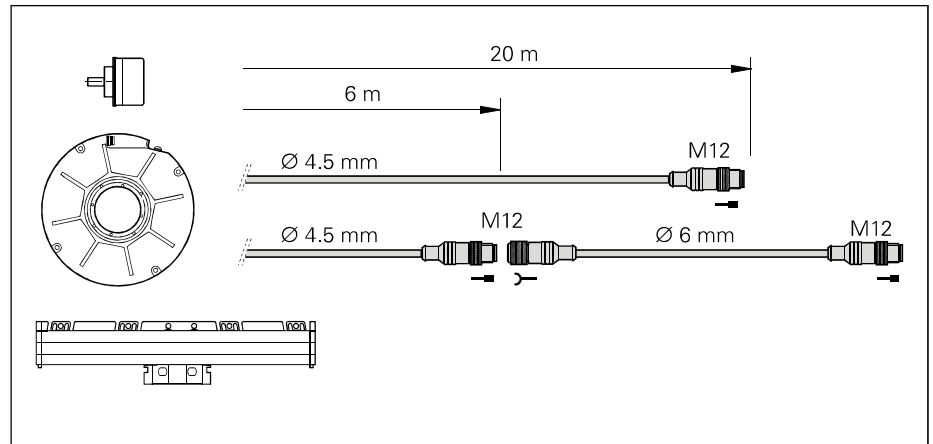

Notes

Due to the data transfer technology, the adapter cable connected directly to the encoder (e.g. $\varnothing \leq 4.5$ mm) must not be longer than 20 m. Greater cable lengths can be realized with an adapter cable no longer than 6 m and an extension cable ($\varnothing 6$ mm).

Along with the voltage drop over the line, other criteria (e.g. clock frequency) can limit the maximum permissible cable length.

Transmission frequencies up to 16 MHz in combination with large cable lengths place high technological demands on the cable. HEIDENHAIN cables are equal to this task, not least because of a cable construction conceived specifically for this application. We recommend using original HEIDENHAIN cables.

Product	Supply voltage U _P of the subsequent electronics	Adapter cable Ø 4.5 mm	Connecting cable Ø 6 mm	Total cable length
RCN 8000	5 V DC	20 m/17 m ¹⁾	–	20 m/17 m
		6 m/6 m	68 m/26 m	74 m/32 m
		1 m/1 m	80 m/39 m	81 m/40 m
	5.25 V DC	20 m/20 m	–	20 m/20 m
		6 m/6 m	83 m/34 m	89 m/40 m
		1 m/1 m	95 m/46 m	96 m/47 m
12 V DC	6 m/6 m	94 m/94 m	Max./Max.	

Product	Supply voltage U _P of the subsequent electronics	Adapter cable within motor	Connecting cable Ø 6 mm	Total cable length
ECN 1325 EQN 1337	5 V DC	0.3 m	Max./64 m	Max./64 m
	5.25 V DC	0.3 m	Max./75 m	Max./75 m

Product	Supply voltage U _P of the subsequent electronics	Encoder cable	Connecting cable Ø 6 mm	Total cable length
LIC 4000	5 V DC	3 m	Max./45 m	Max./48 m
		1 m	Max./53 m	Max./54 m
	5.25 V DC	3 m	Max./55 m	Max./58 m
		1 m	Max./63 m	Max./64 m

Italics: Sensor lines are **not** connected in parallel

Max.: No need to reduce cable length due to the line voltage drop

¹⁾ Due to the line voltage drop, the theoretically possible cable length cannot be used

DRIVE-CLiQ does permit a maximum cable length of 100 m, but this value is reduced by a number of influencing factors:

- Number of joints with DRIVE-CLiQ couplings
- Length factor of the adapter or connecting cable
- Pluggable adapter cable at the HEIDENHAIN encoder
- Length of the HEIDENHAIN adapter cable with compensation factor

The maximum permissible cable length is calculated as follows:

$$n_{MG} \cdot 5 \text{ m} + \frac{4}{3} \cdot L_{AC} + \sum_i k_i \cdot L_i + n_C \cdot 5 \text{ m} \leq 100 \text{ m}$$

- k_i : Length compensation factor¹⁾ of signal line i (4/3 for cable from HEIDENHAIN)
- L_i : Total length¹⁾ of signal line i
- n_C : Number of joints
- n_{MG} : Influence of the encoder, e.g. by a pluggable adapter cable; $n = 1$
- 4/3: Length compensation factor for HEIDENHAIN adapter cables
- L_{AC} : Length of the HEIDENHAIN adapter cable

¹⁾ See technical documentation of the subsequent electronics manufacturer

Electrical safety and electromagnetic compatibility

Electrical safety

The housings of HEIDENHAIN encoders are isolated against internal circuits. The surge voltage of the isolation is 500 V as per EN 60664-1. Contamination level 2 is to be maintained in the micro-environment (see EN 60664-1).

Electromagnetic compatibility (EMC)

When properly installed, and when HEIDENHAIN cables are used, HEIDENHAIN encoders fulfill the requirements for electromagnetic compatibility according to **EMC directive 2004/108/EC** with respect to the generic standards for:

• Immunity (IEC 61000-6-2)

Specifically the following basic standards:

- ESD EN 61000-4-2
- Electromagnetic fields

- Burst EN 61000-4-3
- Burst EN 61000-4-4
- Surge EN 61000-4-5
- Conducted disturbances EN 61000-4-6
- Power frequency magnetic fields EN 61000-4-8
- Voltage dips, short interruptions EN 61000-4-11

• Emission EN 61000-6-4:

Specifically the following product (family) standard:

- For information technology equipment EN 55022

Sources of electrical interference

Electrical interference is caused mainly through capacitive or inductive transfer. Inductive transfer can be introduced into the system over signal lines and input or output terminals.

Typical sources of electrical interference include:

- Strong magnetic fields from transformers, brakes and electric motors
- Relays, contactors and solenoid valves
- High-frequency equipment, pulse devices, and stray magnetic fields from switch-mode power supplies
- AC power lines and supply wires to the above devices

Measures

The following measures must be complied with for disturbance-free operation.

If other actions are taken, specific measures regarding electrical safety and EMC are required.

- Use only original HEIDENHAIN cables. Consider the voltage drop in the supply wires.
- Use connecting elements (such as connectors or terminal boxes) with metal housings. Only the signals and voltage supply of the connected encoder may be routed through these elements (exception: hybrid motor cables from HEIDENHAIN).

- Connect the housings of the encoder, connecting elements and subsequent electronics through the shield of the cable. Ensure that the shield has complete contact over the entire surface (360°). For encoders with more than one electrical connection, refer to the documentation for the respective product.
- Cables with inner and outer shielding are to be kept spatially apart. Connect the inner shield to 0 V of the subsequent electronics. Do not connect the inner shield with the outer shield, neither in the encoder nor in the cable.
- Connect the (outer) shield to functional earth as per the mounting instructions.
- Prevent contact of the shield (e.g. connector housing) with other metal surfaces. Pay attention to this when installing cables.
- Do not install signal cables in the direct vicinity of interference sources (inductive consumers such as contactors, motors, frequency inverters, solenoids, etc.).
 - Sufficient decoupling from interference-signal-conducting cables can usually be achieved by an air clearance of 100 mm or, when cables are in metal ducts, by a grounded partition.
 - A minimum spacing of 200 mm to inductors in switch-mode power supplies is required.
- If compensating currents are to be expected within the overall system, a separate equipotential bonding conductor must be provided. The shield does not have the function of an equipotential bonding conductor.
- Only provide power from PELV systems (see EN 50178 for an explanation of the term) to position encoders, and provide high-frequency grounding with low impedance (see EN 60204-1 Chapter EMC).
- For encoders with 11 μA_{PP} interface: Use only HEIDENHAIN cable ID 244955-01 as extension cable. Overall length: max. 30 m.

