



HEIDENHAIN

araxe

72, rue Yves le Coz
78000 VERSAILLES

tél : 01 30 21 48 49

fax : 01 39 51 16 33

<http://www.araxe.com>

contact@araxe.com

HEIDENHAIN



Modular Angle Encoders

With Magnetic Scanning

The ERM modular encoders from HEIDENHAIN consist of a magnetized scale drum and a scanning unit with magnetoresistive sensor. Their MAGNODUR measuring standard and the magnetoresistive scanning principle make them particularly tolerant to contamination.

Typical applications, usually with reduced accuracy requirements, include machines and equipment with **large hollow shaft diameters** in environments with large amounts of airborne particles and liquids, for example on the spindles of lathes or milling machines.



Information on

- Angle encoders without integral bearing
- Angle encoders with integral bearing
- Rotary encoders
- Encoders for servo drives
- Linear encoders for numerically controlled machine tools
- Exposed linear encoders
- HEIDENHAIN interface electronics
- HEIDENHAIN controls



is available on request as well as on the Internet at www.heidenhain.de.

Comprehensive descriptions of all available interfaces as well as general electrical information are included in the *Interfaces of HEIDENHAIN Encoders* brochure, ID 1078628-xx.

This catalog supersedes all previous editions, which thereby become invalid. The basis for ordering from HEIDENHAIN is always the catalog edition valid when the contract is made.

Standards (ISO, EN, etc.) apply only where explicitly stated in the catalog.

Contents

Overview				
	Selection guide			4
	Areas of application			6
Technical features and mounting information				
	Properties			8
	Measuring principle	Measuring standard Magnetic scanning Incremental measuring method		9
	Measuring accuracy			10
	Mechanical design types and mounting			12
	General mechanical information			15
Specifications	<i>Modular encoder</i>	<i>Series</i>	<i>Signal period (at circumference)</i>	
	With incremental interface	ERM 2200	≈ 200 μm	16
		ERM 2400	≈ 400 μm	18
	With purely serial EnDat interface	ERM 2410	≈ 400 μm	20
	For very high speeds, with incremental interface	ERM 2400	≈ 400 μm	22
		ERM 2900	≈ 1000 μm	24
Electrical connection				
	Interfaces	Incremental signals	 1 V _{PP}	26
				28
		EnDat		29
	Cables and connecting elements	General information		30
		Connecting cables		31
	Diagnostic and testing equipment			32
	Interface electronics			34

Selection guide

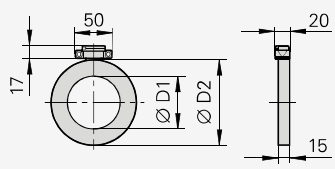
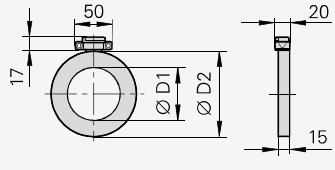
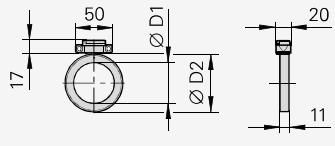
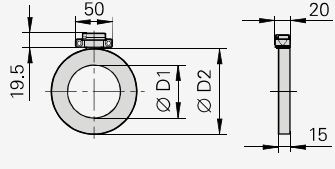
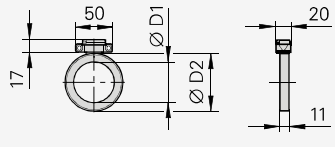
	Overall dimensions in mm	Diameter	Line count	Signal period
ERM 2200 series		D1: 70 mm to 380 mm D2: 113.16 mm to 452.64 mm	1800 to 7200	≈ 200 μm
ERM 2400 series		D1: 40 mm to 410 mm D2: 75.44 mm to 452.64 mm	600 to 3600	≈ 400 μm
		D1: 40 mm to 100 mm D2: 64.37 mm to 128.75 mm	512 to 1024	≈ 400 μm
		D1: 40 mm; 55 mm D2: 64.37 mm; 75.44 mm	512; 600	
ERM 2410 series		D1: 40 mm to 410 mm D2: 75.44 mm to 452.64 mm	600 to 3600	≈ 400 μm
ERM 2900 series		D1: 40 mm to 100 mm D2: 58.06 mm to 120.96 mm	192 to 400	≈ 1000 μm

¹⁾The position value is generated internally from the incremental signals after traverse over two reference marks.

Mechanically permissible speed	Mounting the scale drum	Interface	Model	Page
14500 rpm to 3000 rpm	Fastening by axial screws	~ 1 V _{PP}	AK ERM 2280 TTR ERM 2200C	16
19000 rpm to 3000 rpm	Fastening by axial screws	□TTL	AK ERM 2420 TTR ERM 2400	18
		~ 1 V _{PP}	AK ERM 2480 TTR ERM 2400	
42000 rpm to 20000 rpm	Friction-locked fastening by clamping the drum	~ 1 V _{PP}	AK ERM 2480 TTR ERM 2404	22
33000 rpm; 27000 rpm	Friction-locked fastening by clamping the drum; additional slot for feather key as anti-rotation element	~ 1 V _{PP}	AK ERM 2480 TTR ERM 2405	
19000 rpm to 3000 rpm	Fastening by axial screws	EnDat 2.2/22 ¹⁾	AK ERM 2410 TTR ERM 2400C	20
47000 rpm to 16000 rpm	Friction-locked fastening by clamping the drum	~ 1 V _{PP}	AK ERM 2980 TTR ERM 2904	24



Areas of application

Requirements on productivity and machining quality are steadily increasing. The complexity of workpieces and changing operating conditions due to small batch sizes in part manufacturing are likewise increasing. This must be considered in a production machine's conception and mechanical design in order for such machines to work highly efficiently and precisely.

The robust ERM modular magnetic encoders are especially suited for use in production machines. The large inside diameters available, their small dimensions and the compact design of the scanning head predestine them for

- the C axis of lathes,
- rotary and tilting axes (e.g. for speed measurement on direct drives or for integration in gear stages),
- spindle orientation on milling machines or auxiliary axes.

C axis on lathes

Typical requirements

- Various hollow-shaft diameters
- Resistant to contamination
- Simple installation

Suitable encoder

- ERM 2400 series (AK ERM 2480 and TTR ERM 2400)
- If required, ERM 2200 series (AK ERM 2280 and TTR ERM 2200)

For years, the ERMs have been the preferred encoders for C axes on lathes. Besides their high resistance to contamination, the large inside diameters are also important to allow bar material to be machined without limitations.

Because of this design arrangement, the graduation of the ERM is usually on a much larger diameter than the workpiece. Position errors of the encoder therefore affect workpiece accuracy to a correspondingly reduced degree.

For example, the position error within one signal period, which is approx. $2 \mu\text{m}$ on a scale drum with 2048 lines and a diameter of 257.5 mm, engenders positioning error of only $0.8 \mu\text{m}$ on a workpiece with diameter 100 mm. A smaller workpiece diameter will have an even better value.

The accuracy and reproducibility of the ERM therefore also achieve workpiece accuracy values sufficient for milling operations with lathes (classic C-axis machining).

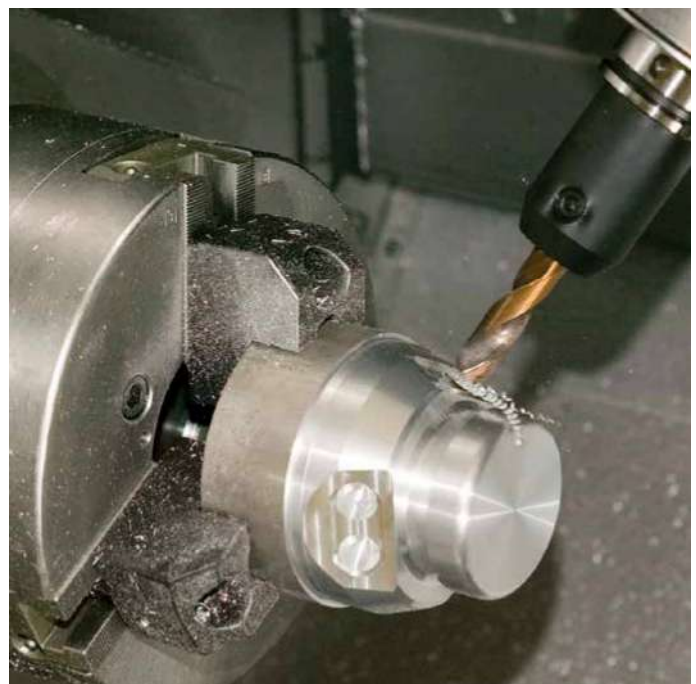
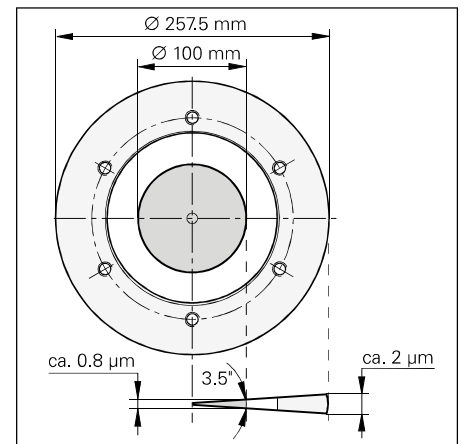

Rotary and tilting axes

Typical requirements

- Medium to high accuracy
- Large hollow-shaft diameters
- Resistant to contamination

Suitable encoder

- ERM 2200 series (AK ERM 2280 and TTR ERM 2200)

Rotary tables and tilting axes require encoders with high signal quality for position and speed control. Encoders with optical measuring standards, for example the RCN series, fulfill these requirements in an ideal way. For medium accuracy requirements magnetic modular encoders can also be used. Due to their small signal period of 200 μm , the ERM 2200 encoders feature particularly low position error within one signal period and therefore permit relatively high axis speed stability. In addition, the typical advantages of magnetic modular encoders, such as tolerance to contamination and large inside diameters, are very helpful in this application.

Spindles on milling machines

Typical requirements

- High shaft speeds
- Small mounting space

Suitable encoder

- ERM 2400 series (AK ERM 2480 and TTR ERM 240x)
- ERM 2900 series (AK ERM 2980 and TTR ERM 2904)

Spindles are among the key components of machine tools and significantly influence their function. Their characteristics are determined by the design, the drive and the bearing systems. The encoders used, however, also have a decisive influence on their performance. They have to permit high rotational speeds and be sufficiently sturdy. Speeds of over 40 000 rpm are no problem for the ERM 2900. In addition the encoders fulfill the requirement for compact dimensions.

If milling and turning operations are to be performed on one machine, increased requirements for spindle accuracy are the result. On complex workpieces, certain machining movements can be performed only through the interaction of feed axes and spindle positions. For example, when manufacturing a thread, a single-point tool needs to assume a defined angular attitude. Here the ERM 2400 encoders with 400 μm signal period come into use. They have better accuracy behavior and, for example, 600 lines on an outside diameter of 75.44 mm. This is significantly more than gears with comparable dimensions.



Properties

The ERM magnetic modular encoders from HEIDENHAIN are characterized by the following properties:

Insensitive to contamination

The encoder in the machine tool is often exposed to heavy loads from cooling lubricants. Particularly with high spindle speeds and large diameters, sealing it becomes very difficult. Here the ERM magnetic modular encoders with their high resistance to contamination are of particular benefit: they can even operate under high humidity, heavy dust loads, and in oily atmospheres.

Large hollow shafts in small installation space

ERM encoders are characterized by compact dimensions and large inside diameters of up to 410 mm. Larger diameters are available upon request.

Simple mounting

Mounting the scale drum and scanning head is decidedly simple and requires little adjustment. The scale drum is centered via the centering collar on its inner circumference. The scanning head is easily positioned with respect to the scale drum by means of a spacer foil. If the recommended mounting tolerances are complied with, it is not necessary to inspect the output signals or readjust them.

High shaft speeds

The scale drums were specially conceived for high shaft speeds. The maximum permissible speeds shown in the specifications also apply for extreme loads. This allows continuous operation at the maximum permissible speed as well as the more demanding reciprocating traverse. Even reciprocating traverse with ongoing braking and acceleration processes, even with direction reversal, can be performed at the maximum permissible speeds. The reciprocation is based on 10 million load reversals and therefore fulfills the requirements for fatigue strength.

The ERM is completely quiet in operation, even at maximum speeds. Ancillary noises, such as from gear-tooth systems, do not occur.

High signal quality

The output signals of the ERM magnetic modular encoders are characterized by high signal quality: Together with the signal period, signal quality is decisive for position error within one signal period. With the magnetic modular encoders, as with many other HEIDENHAIN encoders, this value is significantly better than 1 % of the signal period. For the ERM 2200 and ERM 2400 series, the position error within one signal period is typically less than 0.5 % of the signal period.

Purely serial interface

Besides the incremental output signals, it is possible to transmit the position information as position values over the EnDat 2.2 interface. The sinusoidal scanning signals are highly interpolated in the scanning head and converted to a position value by the integrated counter function. As with all incremental encoders, the absolute reference is determined with the aid of reference marks. A scale drum with distance-coded reference marks is required on these encoders in order to facilitate "homing" the encoder.

The EnDat 2.2 interface offers a large number of other benefits besides serial transmission of the position value, such as automatic self-configuration, monitoring and diagnostic functions, and high reliability of data transmission.

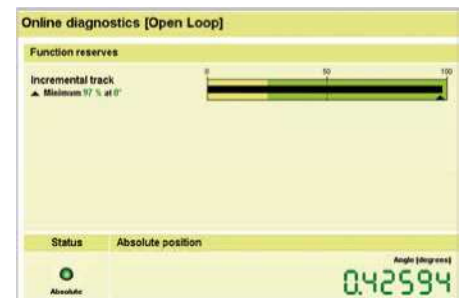

Screen showing the valuation numbers as functional reserves (e.g. with ATS software)



ERM scale drums



Measuring principle

Measuring standard

HEIDENHAIN encoders incorporate measuring standards of periodic structures known as graduations.

Magnetic encoders use a graduation carrier of magnetizable steel alloy. A write head applies strong local magnetic fields in different directions to form a graduation consisting of north poles and south poles (MAGNODUR process).

The following grating periods are possible on the circumference:

- $\approx 200 \mu\text{m}$ with the ERM 2200 series
- $\approx 400 \mu\text{m}$ with the ERM 2400 series
- $\approx 1000 \mu\text{m}$ with the ERM 2900 series

Due to the short distance of effect of electromagnetic interaction and the very narrow scanning gaps required, finer magnetic graduations have significantly tighter mounting tolerances.

Magnetic scanning

The permanently magnetic MAGNODUR graduation is scanned by magnetoresistive sensors. They consist of resistive tracks whose resistance values change in response to a magnetic field. When a voltage is applied to the sensor and the scale drum moves relative to the scanning head, the flowing current is modulated according to the magnetic field.

The special geometric arrangement of the resistive sensors and the manufacture of the sensors on glass substrates ensure a high signal quality. In addition, the large scanning surface allows the signals to be filtered for harmonic waves. These are prerequisites for minimizing position errors within one signal period.

A magnetic structure on a separate track produces a reference mark signal. This makes it possible to assign this absolute position value to exactly one measuring step.

Magnetoresistive scanning is typically used for medium-accuracy applications, or for where the diameter of the machined part is relatively small compared to the scale drum.



Magnetoresistive scanning principle

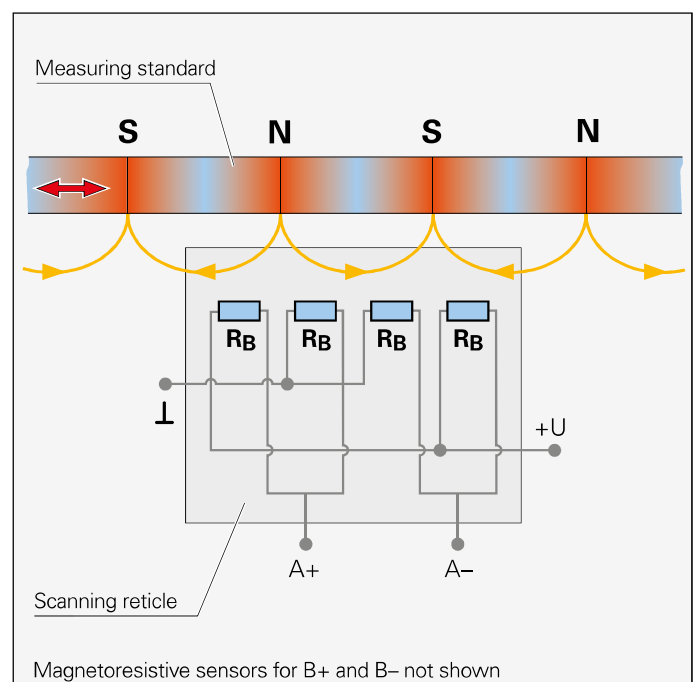

Incremental measuring method

With the incremental measuring method, the graduation consists of a periodic grating structure. The position information is obtained **by counting** the individual increments (measuring steps) from some point of origin. The shaft speed is determined through mathematical derivation of the change in position over time.

Since an absolute reference is required to ascertain positions, the scale drums are provided with an additional track that bears a **reference mark** or multiple reference marks. The absolute position on the scale, established by the reference mark, is gated with exactly one measuring step. The reference mark must therefore be scanned to establish an absolute reference or to find the last selected datum. For scale drums with distance-coded reference marks, the absolute reference is established by merely scanning two neighboring reference marks (see nominal increment *N* in the table).

Scale drums with distance-coded reference marks are identified with a "C" behind the model designation (e.g. TTR ERM 2200C).

With distance-coded reference marks, the **absolute reference** is calculated by counting the signal periods between two reference marks and using the following formulas:

$$\alpha_1 = (\text{abs } A - \text{sgn } A - 1) \times \frac{N}{2} + (\text{sgn } A - \text{sgn } D) \times \frac{\text{abs } M_{RR}}{2}$$

and

$$A = \frac{2 \times \text{abs } M_{RR} - N}{GP}$$

Where:

α_1 = Absolute angular position of the first traversed reference mark to the zero position in degrees

abs = Absolute value

sgn = Sign function (algebraic sign function = +1 or -1)

M_{RR} = Measured value between scanned reference marks in degrees

N = Nominal increment between two fixed reference marks (see tables)

GP = Grating period ($\frac{360^\circ}{\text{Line count}}$)

D = Direction of rotation (+1 or -1)
Rotation as per mating dimensions equals +1

TTR ERM 2200C

Line count z	Number of reference marks	Nominal increment N
1800	36	20°
2048	32	22.5°
2800	50	14.4°
4096	64	11.25°
5200	52	13.85°
7200	90	8°

TTR ERM 2400C

Line count z	Number of reference marks	Nominal increment N
600	20	36°
900	30	24°
1024	32	22.5°
1200	30	24°
1400	40	18°
2048	32	22.5°
2600	52	13.85°
3600	60	12°

Measuring accuracy

The accuracy of angular measurement is mainly determined by

- the quality of the graduation,
- the stability of the graduation carrier.
- the quality of the scanning process,
- the quality of the signal processing electronics,
- the eccentricity of the graduation to the bearing,
- the bearing error, and
- the coupling to the measured shaft.

These factors of influence are comprised of encoder-specific error and application-dependent issues. All individual factors of influence must be considered in order to assess the attainable overall accuracy.

Encoder-specific error

The encoder-specific error is given in the Specifications:

- Accuracy of graduation
- Position error within one signal period

Accuracy of graduation

The accuracy of the graduation $\pm a$ results from its quality. This includes

- the homogeneity and period definition of the graduation,
- the alignment of the graduation on its carrier, and
- the stability of the graduation carrier, in order to also ensure accuracy in the mounted condition.

The accuracy of the graduation $\pm a$ is ascertained under ideal conditions by using a series-produced scanning head to measure position error at positions that are integral multiples of the signal period.

Position error within one signal period

The position error within one signal period $\pm u$ results from the quality of the scanning and—for encoders with integrated pulse-shaping or counter electronics—the quality of the signal-processing electronics. For encoders with sinusoidal output signals, however, the errors of the signal processing electronics are determined by the subsequent electronics.

The following individual factors influence the result:

- the size of the signal period,
- the homogeneity and period definition of the graduation,
- the quality of scanning filter structures,
- the characteristics of the sensors, and
- the stability and dynamics of further processing of the analog signals.

These factors of influence are to be considered when specifying position error within one signal period.

Position error within one signal period $\pm u$ is specified in percent of the signal period. For the ERM magnetic modular encoders with approx. 200 μm or 400 μm , the value is typically better than $\pm 0.5\%$ of the signal period. You will find the specified values in the Specifications.

Position errors within one signal period already become apparent in very small angular motions and in repeated measurements. They especially lead to speed ripples in the speed control loop.

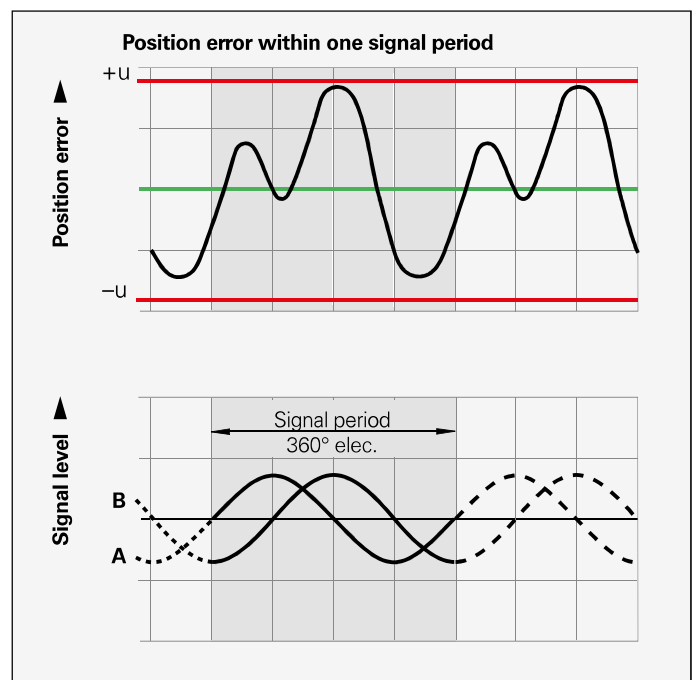
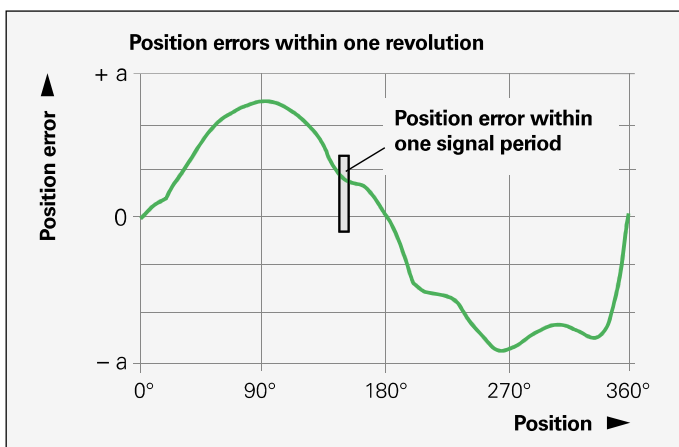

Application-dependent error

The mounting and adjustment of the scanning head, in addition to the given encoder-specific error, normally have a significant effect on the accuracy that can be achieved by **encoders without integral bearings**. Of particular importance are the mounting eccentricity of the graduation and the radial runout of the measured shaft. The application-dependent error values must be measured and calculated individually in order to evaluate the overall accuracy.

In contrast, the specified system accuracy for encoders with integral bearing already includes the error of the bearing and the shaft coupling (see catalog *Angle Encoders with Integral Bearing*).

Errors due to eccentricity of the graduation to the bearing

Under normal circumstances, the graduation will have a certain eccentricity relative to the bearing once the ERM's scale drum is mounted. In addition, dimensional and form deviations of the customer's shaft can result in added eccentricity. The following relationship exists between the eccentricity e , the graduation diameter D and the measuring error $\Delta\varphi$ (see illustration below):

$$\Delta\varphi = \pm 412 \cdot \frac{e}{D}$$

$\Delta\varphi$ = Measuring error in " (angular seconds)

e = Eccentricity of the scale drum to the bearing in μm (1/2 the radial deviation)

D = Scale-drum diameter (= drum outside diameter) in mm

M = Center of graduation

φ = "True" angle

φ' = Scanned angle

Error due to radial runout of the bearing

The equation for the measuring error $\Delta\varphi$ is also valid for radial error of the bearing if the value e is replaced with the eccentricity value, i.e. half of the radial error (half of the displayed value). Bearing compliance to radial shaft loading causes similar errors.

Deformation of the graduation

Error due to deformation of the graduation is not to be ignored. It occurs when the graduation is mounted on an uneven, for example convex, surface.

However, the graduation can also be deformed solely by screw tightening torque. The scale drums are particularly rigid in order to prevent this effect.

A change in direction of motion results additionally in reversal error. It depends on the size of the signal period and the mounting conditions. With ideal mounting conditions it is approx. 0.5 % of the signal period. Deviations of the scanning gap from the nominal value likewise influence the reversal error. HEIDENHAIN therefore recommends measuring the value after mounting for compensation.

Eccentricity of the graduation to the bearing

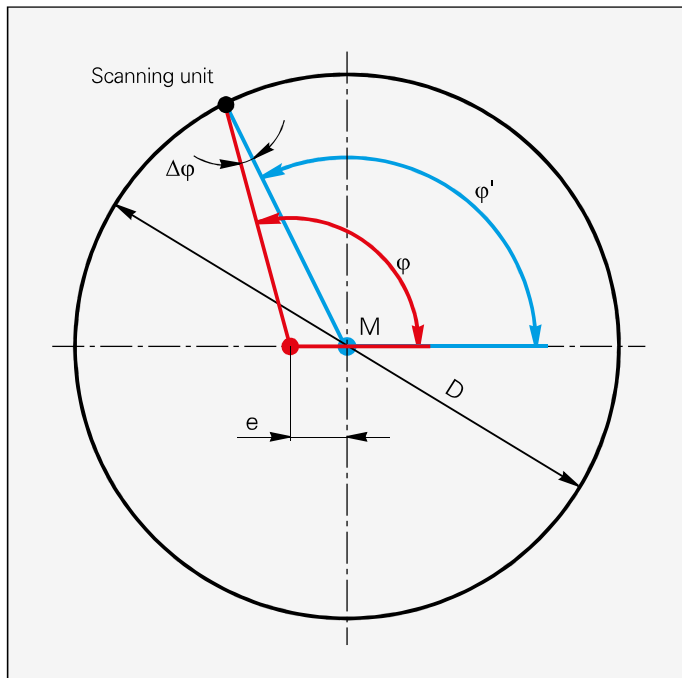

Resultant measured deviations $\Delta\varphi$ for various eccentricity values e as a function of graduation diameter D

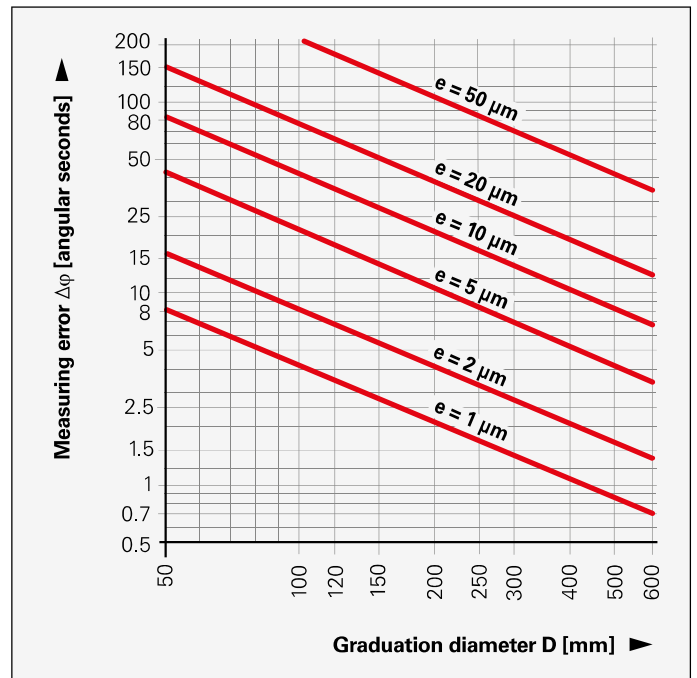

Mechanical design types and mounting

The ERM modular encoders consist of a circumferential scale drum and the corresponding scanning head. The position of the scanning head and graduation relative to each other is determined solely via the machine bearing. However, special design features of the ERM modular encoders assure comparably fast mounting and easy adjustment. The stated values for graduation accuracy and the position error within one signal period can be attained in the application if the requirements are fulfilled (see *Specifications*).

Versions

There are various signal periods available for the ERM modular magnetic encoders (ERM 2200: $\approx 200 \mu\text{m}$, ERM 2400: $\approx 400 \mu\text{m}$, ERM 2900: $\approx 1 \text{ mm}$). This results in different line counts for the same outside diameter.

The scale drums are available in three versions. They differ essentially in the type of mounting. All scale drums feature a centering collar on the inside diameter.

TTR ERM 2200 and TTR ERM 2400 scale drums

For mounting, the scale drums are slid onto the mating shaft and fastened axially with screws.

TTR ERM 2x0x scale drum

The **TTR ERM 2404**, **TTR ERM 2405** and **TTR ERM 2904** scale drums are fastened only by a friction-locked connection to the mating surface. The clamping of the scale drum depends on the mounting situation.

The clamping force must be applied evenly over the plane surface of the drum. The necessary mounting elements depend on the design of the customer's equipment, and are therefore the responsibility of the customer. The frictional connection must be strong enough to prevent unintentional rotation or skewing in axial and radial directions, even at high speeds and accelerations. The scale drum must not be modified for this purpose, such as by drilling holes or countersinks in it.

The **TTR ERM 2404** and **TTR ERM 2904** versions feature a smooth inside drum surface. Only a friction-locked connection (clamping of the drum) is to be used to prevent them from rotating unintentionally. The **TTR ERM 2405** scale drums feature a keyway. The feather key is intended only for the prevention of unintentional rotation and not for the transmission of torque. The special shape of the drum's inner side ensures stability even at the maximum permissible speeds.

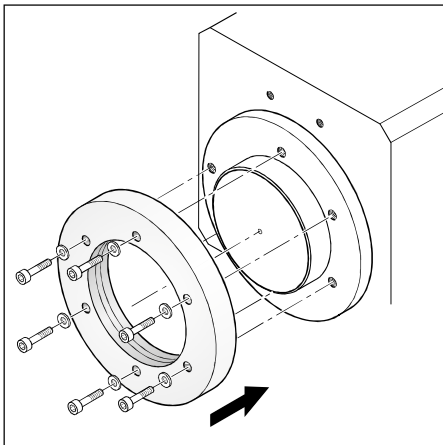

Mounting of the scale drum
TTR ERM 2400
TTR ERM 2200

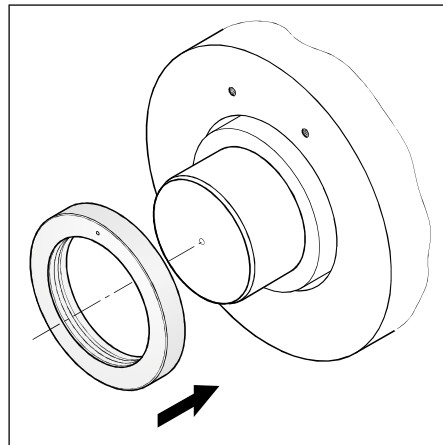

Mounting of the scale drum
ERM 2404 scale drum
TTR ERM 2904

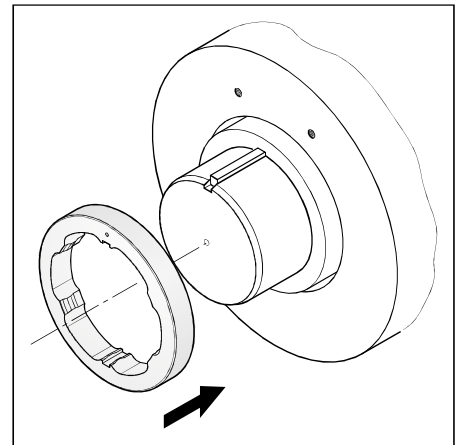

Mounting of the scale drum
TTR ERM 2405

Centering the scale drum

Because the attainable total accuracy is dominated by mounting error (mainly through eccentricity), special attention must be placed on centering the scale drum. Depending on the encoder and mounting method, various methods of centering the scale drums are possible in order to minimize the eccentricity errors that occur in practice.

Centering by centering collar

The scale drum is pushed or shrunk onto the shaft. This very simple method requires an exact shaft geometry and bearing quality to meet the corresponding accuracy requirements.

The scale drum is centered via the centering collar on its inner circumference. HEIDENHAIN recommends a slight oversize of the shaft on which the ERM 2x00 scale drum is to be mounted. For easier mounting, the scale drum may be slowly warmed on a heating plate over a period of approx. 10 minutes to a temperature of at most 100 °C. In order to check the radial runout and assess the resulting deviations, testing of the shaft's rotational accuracy before mounting is recommended.

Back-off threads are used for dismounting the scale drums.

Mounting the scanning head

In order to mount the scanning head, the provided spacer foil is applied to the surface of the circumferential scale drum. The scanning head is pressed against the foil, fastened, and the foil is removed.

Test film for magnetic graduation

A test film can be used to make the magnetic graduation visible. It enables the user to easily check whether there is any damage to the magnetic graduation, such as demagnetization from a tool. The test film can be "cleaned" with the aid of a demagnetization device and therefore used repeatedly. The test film and demagnetization device are available as accessories.

Mounting clearance

The mounting clearance (gap between scanning head and scale drum) depends on the encoder's signal period. As a result, the spacer foils for mounting the scanning head are of varying thicknesses. Deviations of the scale-to-reticle gap from the ideal value negatively influence the signal amplitude.

Measuring with two scanning heads

Error caused by the eccentricity of the graduation to the bearing are compensated with the aid of a second scanning head that is arranged at an angle of $180^\circ \pm 5^\circ$ to the first one. The incremental signals of both scanning heads are digitally offset in an external EIB 1500 interface box with a high subdivision factor and are transmitted as absolute position values after the reference mark is scanned (see the Product Information for *EIB 1500*).

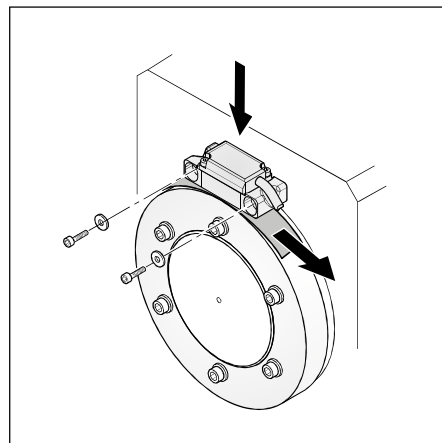

Mounting the scanning head, e.g. AK ERM 2480

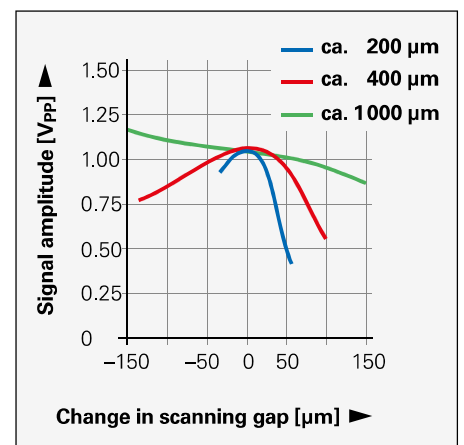

Typical correlation of signal amplitude and scanning gap (mounting clearance)

General mechanical information

Protection against contact

After encoder installation, all rotating parts must be protected against accidental contact during operation.

Acceleration

Encoders are subject to various types of acceleration during operation and mounting:

- The indicated maximum values for **vibration resistance** are valid according to EN 60068-2-6.
- The maximum permissible acceleration values (semi-sinusoidal shock) for **shock and impact** are valid for 6 ms (EN 60068-2-27). Under no circumstances should a hammer or similar implement be used to adjust or position the encoder.

Temperature range

The **operating temperature range** indicates the ambient temperature limits between which the encoders will function properly.

The **storage temperature range** of -30 °C to $+70\text{ °C}$ applies when the unit remains in its packaging.

Shaft speeds

The maximum permissible shaft speeds were determined according to FKM guidelines. This guideline serves as mathematical attestation of component strength with regard to all relevant influences and it reflects the latest state of the art. The requirements for fatigue strength (10 million reversals of load) were considered in the calculation of the permissible shaft speeds. Because installation has a significant influence, all requirements and directions in the specifications and mounting instructions must be followed for the shaft-speed data to be valid.

Expendable parts

HEIDENHAIN encoders contain components that are subject to wear, depending on the application and handling. These include in particular moving cables. Pay attention to the minimum permissible bending radii.

Mounting

Work steps to be performed and dimensions to be maintained during mounting are specified solely in the mounting instructions supplied with the unit. All data in this catalog regarding mounting are therefore provisional and not binding; they do not become terms of a contract.

System tests

Encoders from HEIDENHAIN are usually integrated as components in larger systems. Such applications require **comprehensive tests of the entire system** regardless of the specifications of the encoder.

The specifications shown in this brochure apply to the specific encoder, and not to the entire system. Any operation of the encoder outside of the specified range or for any applications other than the intended applications is at the user's own risk.

In safety-related systems, the higher-level system must verify the position value of the encoder after switch-on.

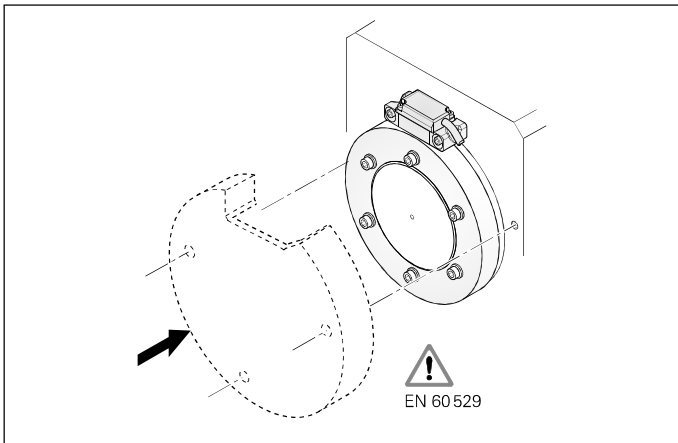

Protection against contact

ERM 2200 series

- Consisting of AK ERM 2280 scanning head and TTR ERM 2200C scale drum
- Modular encoders with magnetic scanning principle
- Signal period approx. 200 μm (on circumference)
- For rotary and tilting axes

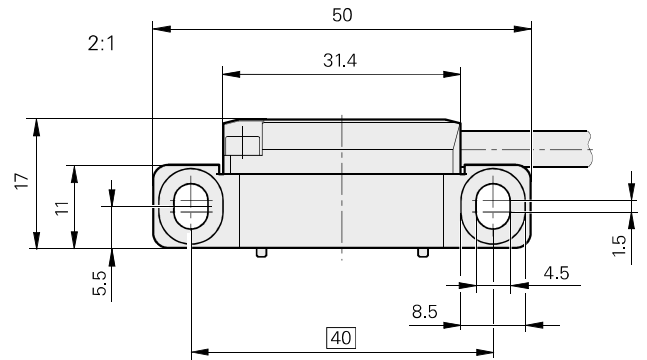
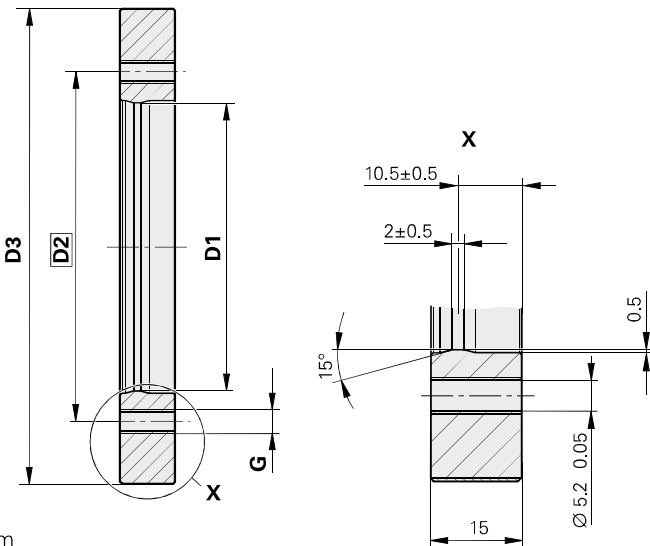
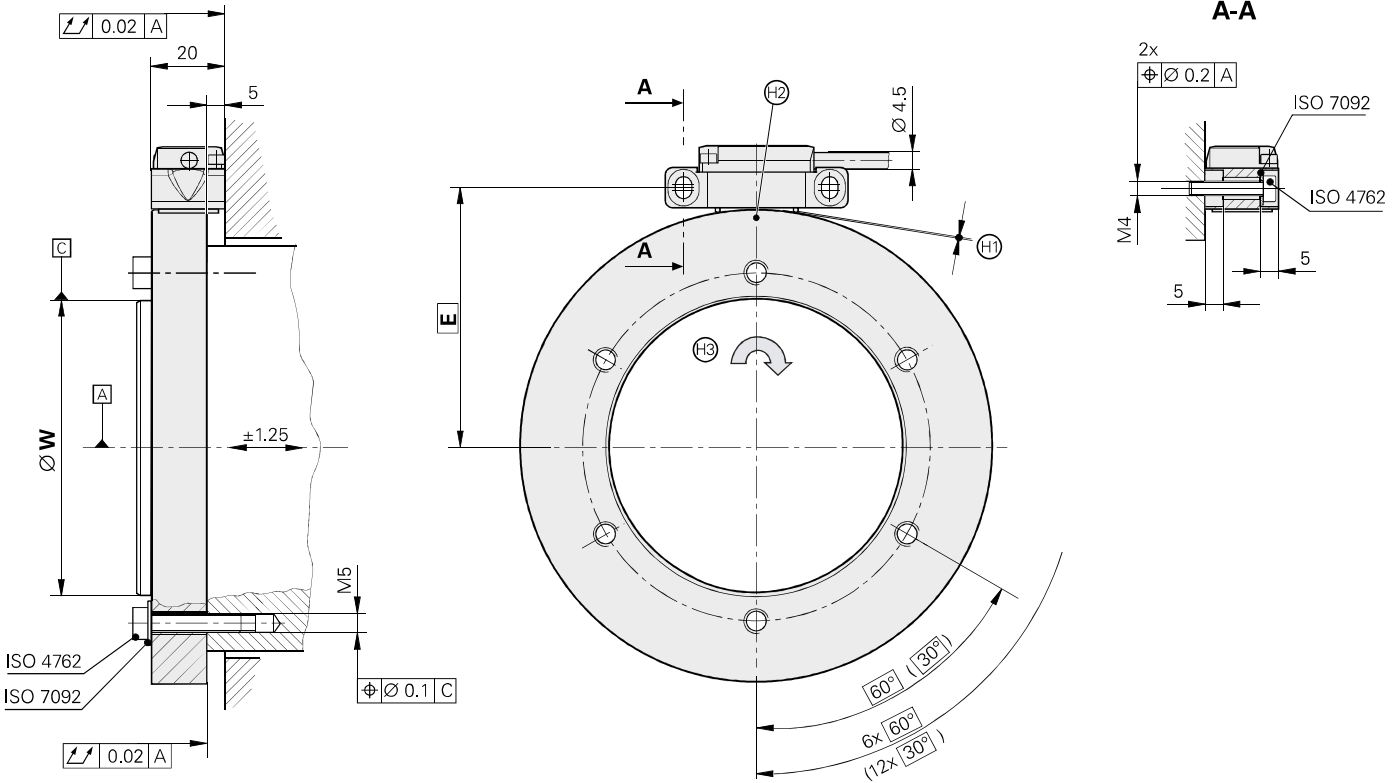

mm
 Tolerancing ISO 8015
 ISO 2768 - m H
 < 6 mm: ±0.2 mm

- ▢ = Bearing
- ⊕ = Mounting clearance of 0.05 mm set with spacer foil
- ⊕ = Marker for reference mark, position tolerance with respect to reference mark ±5°
- ⊕ = Direction of shaft rotation for output signals according to interface description

D1	W	D2	D3	E	G
∅ 70 0/-0.008	∅ 70 +0.010/+0.002	∅ 85	∅ 113.16	62.3	6x M6
∅ 80 0/-0.008	∅ 80 +0.010/+0.002	∅ 95	∅ 128.75	70.1	6x M6
∅ 130 0/-0.012	∅ 130 +0.015/+0.003	∅ 145	∅ 176.03	93.7	6x M6
∅ 180 0/-0.012	∅ 180 +0.015/+0.003	∅ 195	∅ 257.50	134.5	6x M6
∅ 260 0/-0.016	∅ 260 +0.020/+0.004	∅ 275	∅ 326.90	169.2	6x M6
∅ 380 0/-0.018	∅ 380 +0.022/+0.004	∅ 395	∅ 452.64	232.0	12x M6

Scanning head	AK ERM 2280
Interface	$\sim 1 V_{pp}$
Cutoff frequency -3 dB	≥ 300 kHz
Signal period	≈ 200 μ m
Line count*	See "Scale drum"
Electrical connection*	Cable 1 m, with or without coupling
Cable length	≤ 150 m (with HEIDENHAIN cable)
Voltage supply	5 V DC ± 0.5 V
Current requirement	≤ 150 mA (without load)
Vibration 55 to 2000 Hz Shock 6 ms	≤ 400 m/s ² (EN 60068-2-6) ≤ 1000 m/s ² (EN 60068-2-27)
Operating temperature	-10 °C to +60 °C
Protection EN 60 529	IP67
Mass	≈ 0.15 kg (with cable)

Scale drum	TTR ERM 2200C					
Measuring standard	MAGNADUR graduation; signal period of approx. 200 μ m					
Line count*	1800	2048	2800	4096	5200	7200
Position error per signal period ¹⁾	$\pm 5.5''$	$\pm 4.5''$	$\pm 3.5''$	$\pm 2.5''$	$\pm 2''$	$\pm 1.5''$
Accuracy of graduation	$\pm 7''$	$\pm 6''$	$\pm 5''$	$\pm 3.5''$	$\pm 3''$	$\pm 2.5''$
Reference mark	Distance-coded					
Angle for absolute reference	$\leq 20^\circ$	$\leq 22.5^\circ$	$\leq 14.4^\circ$	$\leq 11.25^\circ$	$\leq 13.85^\circ$	$\leq 8^\circ$
Inside diameter*	70 mm	80 mm	130 mm	180 mm	260 mm	380 mm
Outside diameter	113.16 mm	128.75 mm	176.03 mm	257.50 mm	326.90 mm	452.64 mm
Mech. permissible speed	≤ 14500 rpm	≤ 13000 rpm	≤ 9000 rpm	≤ 6000 rpm	≤ 4500 rpm	≤ 3000 rpm
Moment of inertia of rotor	$1.6 \cdot 10^{-3}$ kgm ²	$2.7 \cdot 10^{-3}$ kgm ²	$7.7 \cdot 10^{-3}$ kgm ²	$38 \cdot 10^{-3}$ kgm ²	$76 \cdot 10^{-3}$ kgm ²	$235 \cdot 10^{-3}$ kgm ²
Permissible axial motion	± 1.25 mm					
Mass approx.	0.69 kg	0.89 kg	1.2 kg	3.0 kg	3.5 kg	5.4 kg

* Please select or indicate when ordering

¹⁾ The position error within one signal period and the accuracy of the graduation result together in the encoder-specific error; for additional error through mounting and the bearing of the measured shaft, see *Measuring accuracy*

Other line counts/dimensions upon request

ERM 2400 series

- Consisting of AK ERM 24x0 scanning head and TTR ERM 2400 scale drum
- Modular encoders with magnetic scanning principle
- Signal period approx. 400 μm (on circumference)
- For C axis on lathes

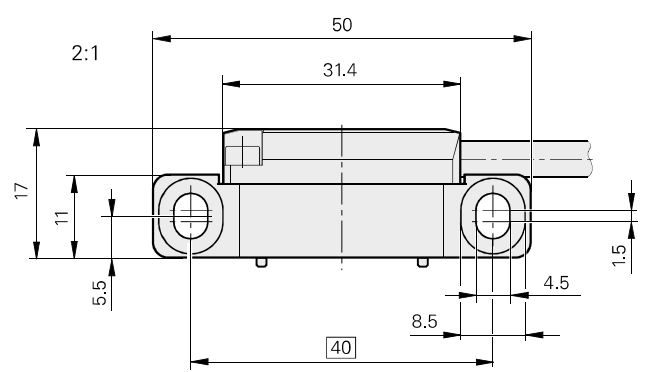
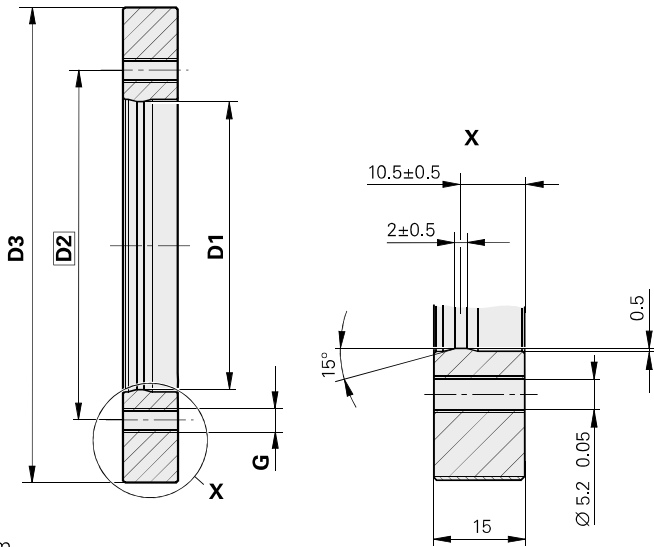
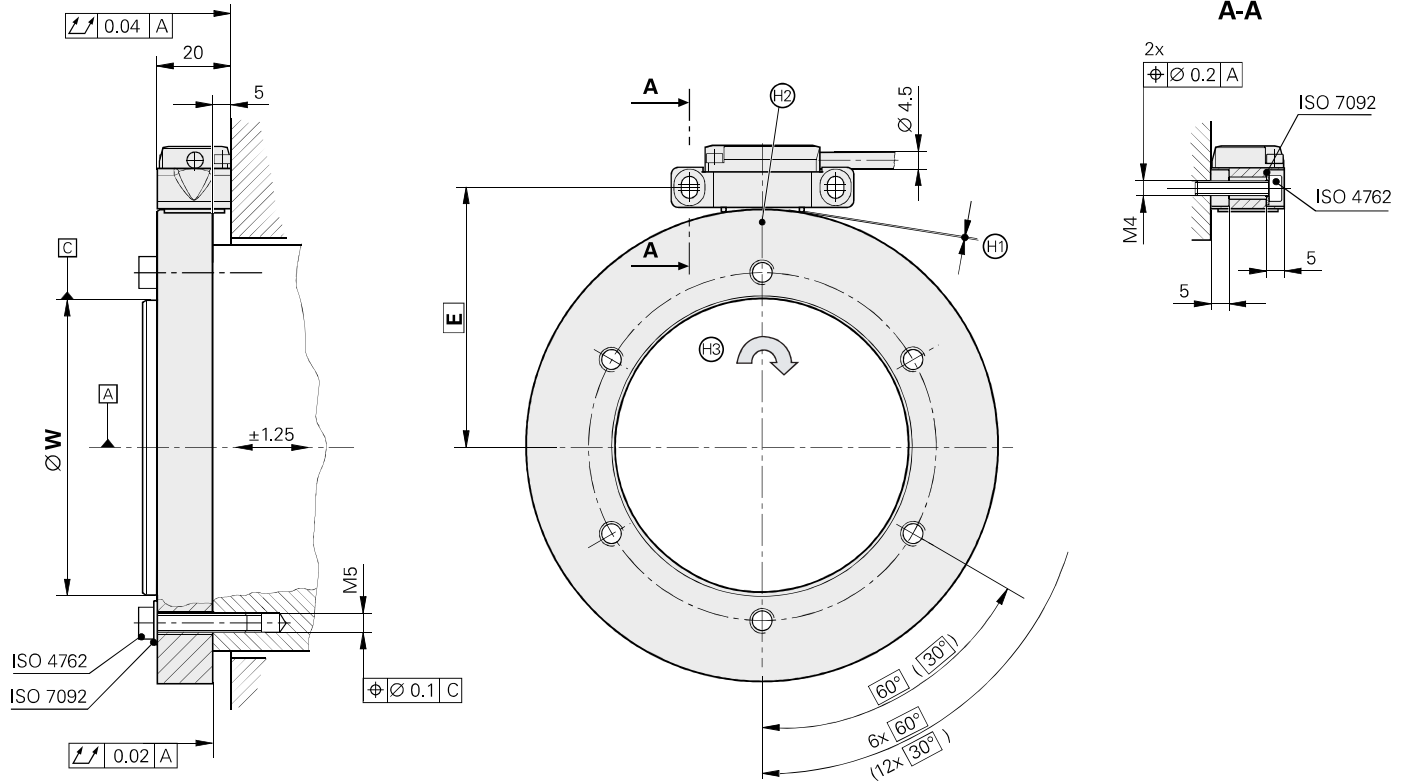

mm
 Tolerancing ISO 8015
 ISO 2768 - m H
 < 6 mm: ±0.2 mm

- Ⓜ = Bearing
- Ⓜ = Mounting clearance of 0.15 mm set with spacer foil
- Ⓜ = Marker for reference mark, position tolerance with respect to reference mark ±5°
- Ⓜ = Direction of shaft rotation for output signals according to interface description

D1	W	D2	D3	E	G
∅ 40 -0.007	∅ 40 +0.009/+0.002	∅ 50	∅ 75.44	43.4	6x M6
∅ 70 -0.008	∅ 70 +0.010/+0.002	∅ 85	∅ 113.16	62.3	6x M6
∅ 80 -0.008	∅ 80 +0.010/+0.002	∅ 95	∅ 128.75	70.1	6x M6
∅ 120 -0.010	∅ 120 +0.013/+0.003	∅ 135	∅ 150.88	81.2	6x M6
∅ 130 -0.012	∅ 130 +0.015/+0.003	∅ 145	∅ 176.03	93.7	6x M6
∅ 180 -0.012	∅ 180 +0.015/+0.003	∅ 195	∅ 257.50	134.5	6x M6
∅ 220 -0.014	∅ 220 +0.018/+0.004	∅ 235	∅ 257.50	134.5	6x M6
∅ 295 -0.016	∅ 295 +0.020/+0.004	∅ 310	∅ 326.90	169.2	6x M6
∅ 410 -0.020	∅ 410 +0.025/+0.005	∅ 425	∅ 452.64	232.0	12x M6

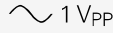
Scanning head	AK ERM 2420	AK ERM 2480
Interface	 TTL	 1 V _{PP}
Cutoff frequency –3 dB Scanning frequency	– ≤ 350 kHz	≥ 300 kHz –
Signal period	≈ 400 μm	
Line count*	See "Scale drum"	
Electrical connection*	Cable 1 m, with or without coupling	
Cable length	≤ 100 m (with HEIDENHAIN cable)	≤ 150 m (with HEIDENHAIN cable)
Voltage supply	5 V DC ± 0.5 V	
Current requirement	≤ 150 mA (without load)	
Vibration 55 to 2000 Hz Shock 6 ms	≤ 400 m/s ² (EN 60068-2-6) ≤ 1000 m/s ² (EN 60068-2-27)	
Operating temperature	–10 °C to +100 °C	
Protection EN 60 529	IP67	
Mass	≈ 0.15 kg (with cable)	

Scale drum	TTR ERM 2400									
Measuring standard	MAGNADUR graduation; signal period of approx. 400 μm									
Line count*	600	900	1024	1200	1400	2048	2048	2600	3600	
Position error per signal period ¹⁾	±15.5"	±10.5"	±9"	±8"	±6.5"	±4.5"	±4.5"	±3.5"	±3"	
Accuracy of graduation	±11"	±8"	±7"	±6"	±5.5"	±4"	±5"	±4"	±3.5"	
Reference mark*	TTR ERM 2400: One TTR ERM 2400C: Distance-coded									
Inside diameter*	40 mm	70 mm	80 mm	120 mm	130 mm	180 mm	220 mm	295 mm	410 mm	
Outside diameter	75.44 mm	113.16 mm	128.75 mm	150.88 mm	176.03 mm	257.50 mm	257.50 mm	326.90 mm	452.64 mm	
Mech. permissible speed	≤ 19000 rpm	≤ 14500 rpm	≤ 13000 rpm	≤ 10500 rpm	≤ 9000 rpm	≤ 6000 rpm	≤ 6000 rpm	≤ 4500 rpm	≤ 3000 rpm	
Moment of inertia of rotor	0.34 · 10 ⁻³ kgm ²	1.6 · 10 ⁻³ kgm ²	2.7 · 10 ⁻³ kgm ²	3.5 · 10 ⁻³ kgm ²	7.7 · 10 ⁻³ kgm ²	38 · 10 ⁻³ kgm ²	23 · 10 ⁻³ kgm ²	44 · 10 ⁻³ kgm ²	156 · 10 ⁻³ kgm ²	
Permissible axial motion	±1.25 mm									
Mass approx.	0.35 kg	0.69 kg	0.89 kg	0.72 kg	1.2 kg	3.0 kg	1.6 kg	1.7 kg	3.2 kg	

* Please select or indicate when ordering

¹⁾ The position error within one signal period and the accuracy of the graduation result together in the encoder-specific error; for additional error through mounting and the bearing of the measured shaft, see *Measuring accuracy*

Other line counts/dimensions upon request

ERM 2410 series

- Consisting of AK ERM 2410 scanning head and TTR ERM 2400C scale drum
- Modular encoders with magnetic scanning principle
- For C axis on lathes
- Integrated counting function for position-value output
- Absolute position value after traverse of two reference marks

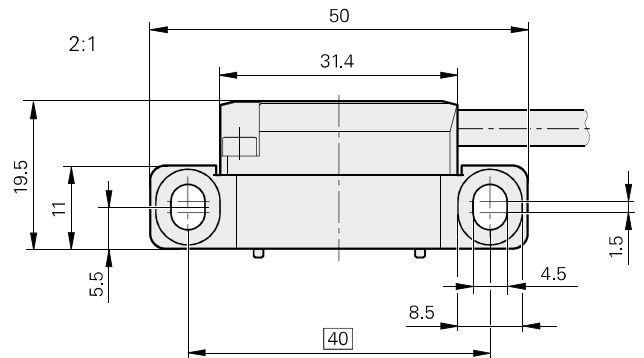
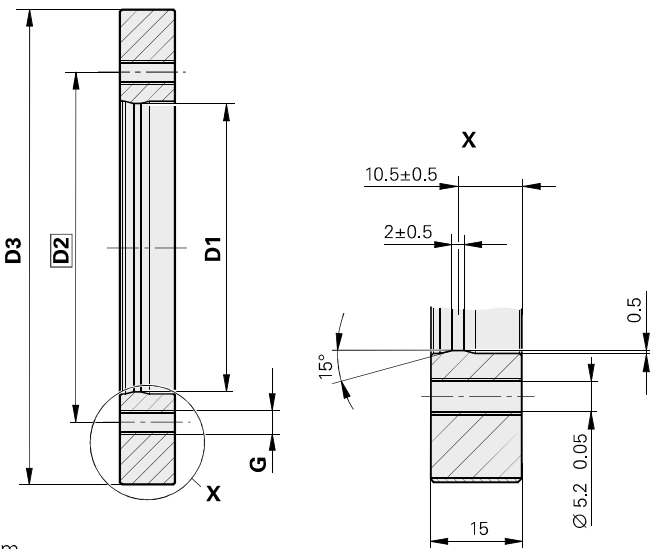
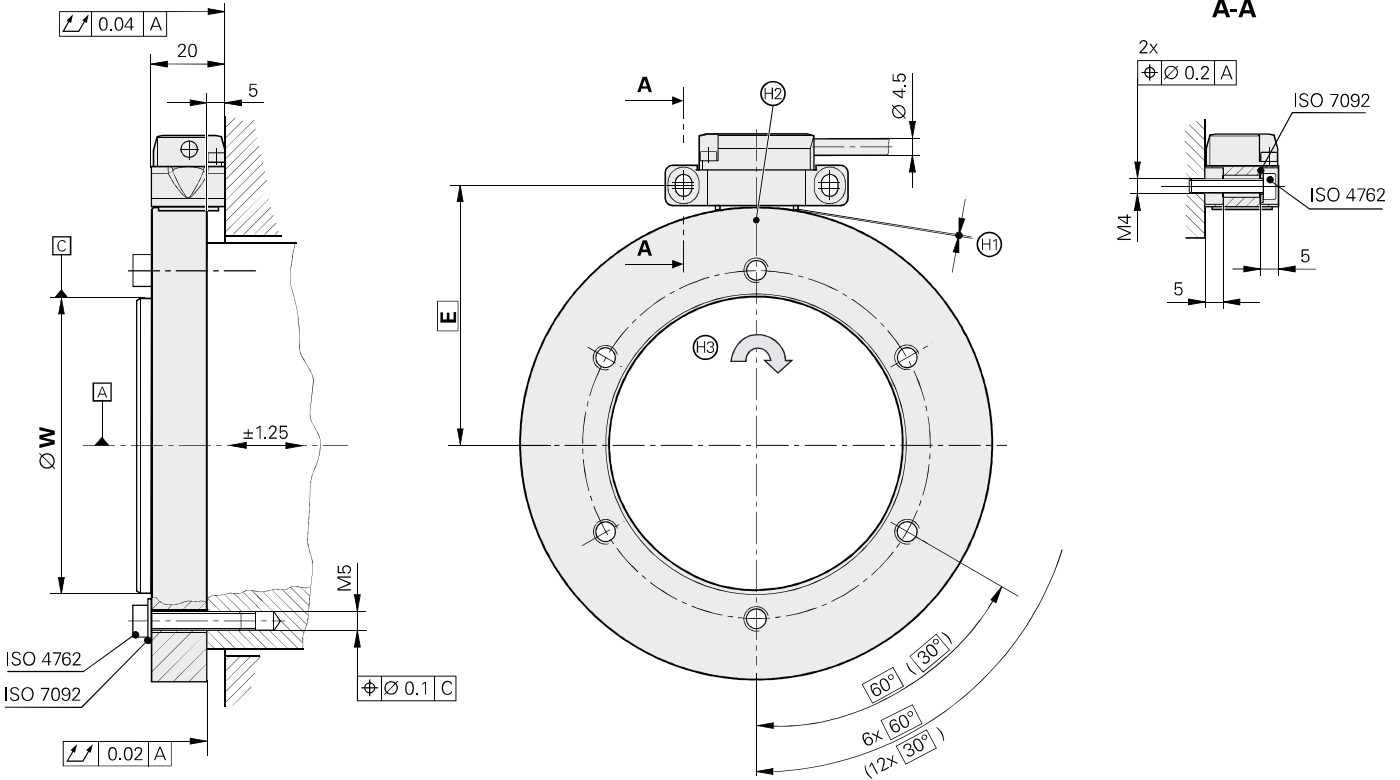

mm

 Tolerancing ISO 8015
 ISO 2768 - m H
 < 6 mm: ±0.2 mm

- = Bearing
- ⊕ = Mounting clearance of 0.15 mm set with spacer foil
- ⊙ = Marker for reference mark, position tolerance with respect to reference mark ±5°
- ⊙ = Direction of shaft rotation for output signals according to interface description

D1	W	D2	D3	E	G
Ø 40 -0.007	Ø 40 +0.009/+0.002	Ø 50	Ø 75.44	43.4	6x M6
Ø 70 -0.008	Ø 70 +0.010/+0.002	Ø 85	Ø 113.16	62.3	6x M6
Ø 80 -0.008	Ø 80 +0.010/+0.002	Ø 95	Ø 128.75	70.1	6x M6
Ø 120 -0.010	Ø 120 +0.013/+0.003	Ø 135	Ø 150.88	81.2	6x M6
Ø 130 -0.012	Ø 130 +0.015/+0.003	Ø 145	Ø 176.03	93.7	6x M6
Ø 180 -0.012	Ø 180 +0.015/+0.003	Ø 195	Ø 257.50	134.5	6x M6
Ø 220 -0.014	Ø 220 +0.018/+0.004	Ø 235	Ø 257.50	134.5	6x M6
Ø 295 -0.016	Ø 295 +0.020/+0.004	Ø 310	Ø 326.90	169.2	6x M6
Ø 410 -0.020	Ø 410 +0.025/+0.005	Ø 425	Ø 452.64	232.0	12x M6

Scanning head	AK ERM 2410
Interface	EnDat 2.2 (absolute position value after scanning two reference marks in "position value 2")
Ordering designation	EnDat22
Integrated interpolation	16 384-fold (14 bits)
Clock frequency	≤ 8 MHz
Calculation time t_{cal}	≤ 5 μs
Signal period	≈ 400 μm
Line count*	See "Scale drum"
Electrical connection	Cable, 1 m, with M12 coupling (8-pin)
Cable length	≤ 150 m (with HEIDENHAIN cable)
Voltage supply	3.6 V to 14 V DC
Power consumption ¹⁾	At 14 V: 110 mA; at 3.6 V: 300 mA (maximum)
Current consumption (typical)	At 5 V: 90 mA (without load)
Vibration 55 to 2000 Hz Shock 6 ms	≤ 300 m/s ² (EN 60068-2-6) ≤ 1000 m/s ² (EN 60068-2-27)
Operating temperature	-10 °C to +100 °C
Protection EN 60 529	IP67
Mass	≈ 0.15 kg (with cable)

Scale drum	TTR ERM 2400C									
Measuring standard	MAGNADUR graduation, signal period approx. 400 μm									
Line count*	600	900	1024	1200	1400	2048	2048	2600	3600	
Positions per revolution	9830400	14745600	16777216	19660800	22937600	33554432	33554432	42598400	58982400	
Position error per signal period	±15.5"	±10.5"	±9"	±8"	±6.5"	±4.5"	±4.5"	±3.5"	±3"	
Accuracy of the graduation²⁾	±11"	±8"	±7"	±6"	±5.5"	±4"	±5"	±4"	±3.5"	
Reference marks	Distance-coded									
Angle for absolute reference	≤ 36°	≤ 24°	≤ 22.5°	≤ 24°	≤ 18°	≤ 22.5°	≤ 22.5°	≤ 13.85°	≤ 12°	
Inside diameter*	40 mm	70 mm	80 mm	120 mm	130 mm	180 mm	220 mm	295 mm	410 mm	
Outside diameter	75.44 mm	113.16 mm	128.75 mm	150.88 mm	176.03 mm	257.50 mm	257.50 mm	326.90 mm	452.64 mm	
Mech. permissible speed	≤ 19000 rpm	≤ 14500 rpm	≤ 13000 rpm	≤ 10500 rpm	≤ 9000 rpm	≤ 6000 rpm	≤ 6000 rpm	≤ 4500 rpm	≤ 3000 rpm	
Moment of inertia of rotor	0.34 · 10 ⁻³ kgm ²	1.6 · 10 ⁻³ kgm ²	2.7 · 10 ⁻³ kgm ²	3.5 · 10 ⁻³ kgm ²	7.7 · 10 ⁻³ kgm ²	38 · 10 ⁻³ kgm ²	23 · 10 ⁻³ kgm ²	44 · 10 ⁻³ kgm ²	156 · 10 ⁻³ kgm ²	
Permissible axial motion	±1.25 mm									
Mass approx.	0.35 kg	0.69 kg	0.89 kg	0.72 kg	1.2 kg	3.0 kg	1.6 kg	1.7 kg	3.2 kg	

* Please select when ordering

¹⁾ See *General Electrical Information*

²⁾ The position error within one signal period and the accuracy of the graduation result together in the encoder-specific error; for additional error through mounting and the bearing of the measured shaft, see *Measuring accuracy*

Other line counts/dimensions upon request

ERM 2400 series

- Consisting of AK ERM 2480 scanning head and TTR ERM 2404/2405 scale drum
- Modular encoders with magnetic scanning principle
- Signal period approx. 400 µm (on circumference)
- For spindles on milling machines

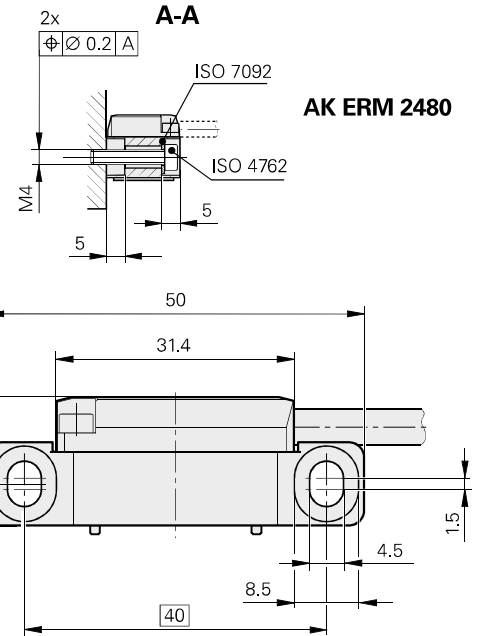
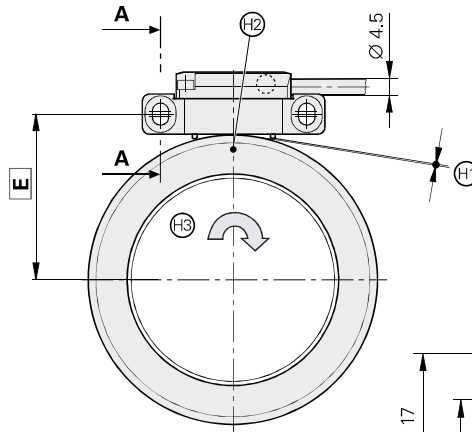
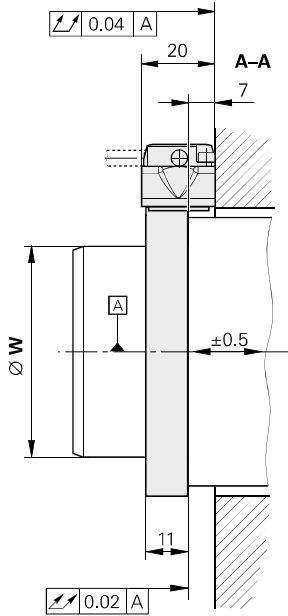

TTRERM 2404

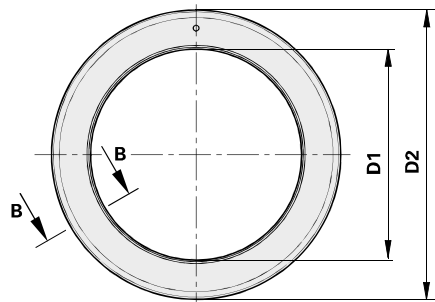

TTRERM 2405

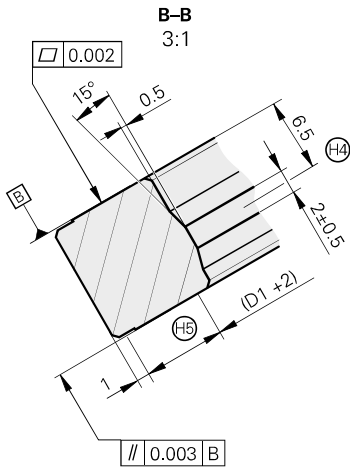
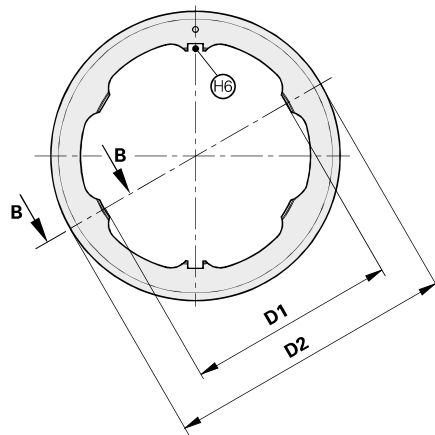

mm

 Tolerancing ISO 8015
 ISO 2768 - m H
 < 6 mm: ±0.2 mm

- ⊠ = Bearing
- ⊕ = Mounting distance of 0.15 mm set with spacer foil
- ⊗ = Marker for reference mark, position tolerance with respect to reference mark ±5°
- ⊙ = Direction of shaft rotation for output signals according to interface description
- ⊕ = Centering collar
- ⊕ = Clamping area (applies to both sides)
- ⊕ = Slot for feather key 4 x 4 x 10 (as per DIN 6885 shape A)

D1	W	D2	E
Ø 40 +0.010/+0.002	Ø 40 0/-0.006	Ø 64.37	37.9
Ø 55 +0.010/+0.002	Ø 55 0/-0.006	Ø 75.44	43.4
Ø 80 +0.010/+0.002	Ø 80 0/-0.006	Ø 113.16	62.3
Ø 100 +0.010/+0.002	Ø 100 0/-0.006	Ø 128.75	70.0

Scanning head	AK ERM 2480
Interface	$\sim 1 V_{PP}$
Cutoff frequency -3 dB	≥ 300 kHz
Signal period	≈ 400 μ m
Line count*	See "Scale drum"
Electrical connection*	Cable 1 m, with or without coupling, tangential or axial cable outlet
Cable length	≤ 150 m (with HEIDENHAIN cable)
Voltage supply	5 V DC ± 0.5 V
Current requirement	≤ 150 mA (without load)
Vibration 55 to 2000 Hz Shock 6 ms	≤ 400 m/s ² (EN 60068-2-6) ≤ 1000 m/s ² (EN 60068-2-27)
Operating temperature	-10 °C to +100 °C
Protection EN 60 529	IP67
Mass	≈ 0.15 kg (with cable)

Scale drum	ERM 2404 scale drum				TTR ERM 2405	
Measuring standard	MAGNADUR graduation; signal period of approx. 400 μ m					
Line count*	512	600	900	1 024	512	600
Position error per signal period ¹⁾	$\pm 18''$	$\pm 15.5''$	$\pm 10.5''$	$\pm 9''$	$\pm 18''$	$\pm 15.5''$
Accuracy of graduation	$\pm 17''$	$\pm 14''$	$\pm 10''$	$\pm 9''$	$\pm 17''$	$\pm 14''$
Reference mark	One					
Inside diameter*	40 mm	55 mm	80 mm	100 mm	40 mm	55 mm
Outside diameter	64.37 mm	75.44 mm	113.16 mm	128.75 mm	64.37 mm	75.44 mm
Mech. permissible speed	≤ 42000 rpm	≤ 36000 rpm	≤ 22000 rpm	≤ 20000 rpm	≤ 33000 rpm	≤ 27000 rpm
Moment of inertia of rotor	$0.12 \cdot 10^{-3}$ kgm ²	$0.19 \cdot 10^{-3}$ kgm ²	$1.0 \cdot 10^{-3}$ kgm ²	$1.4 \cdot 10^{-3}$ kgm ²	$0.11 \cdot 10^{-3}$ kgm ²	$0.17 \cdot 10^{-3}$ kgm ²
Permissible axial motion	± 0.5 mm					
Mass approx.	0.17 kg	0.17 kg	0.42 kg	0.43 kg	0.15 kg	0.15 kg

* Please select or indicate when ordering

¹⁾ The position error within one signal period and the accuracy of the graduation result together in the encoder-specific error; for additional error through mounting and the bearing of the measured shaft, see *Measuring accuracy*

Other line counts/dimensions upon request

ERM 2900 series

- Consisting of AK ERM 2980 scanning head and TTR ERM 2904 scale drum
- Modular encoders with magnetic scanning principle
- Signal period approx. 1000 μm (on circumference)
- For spindles on milling machines

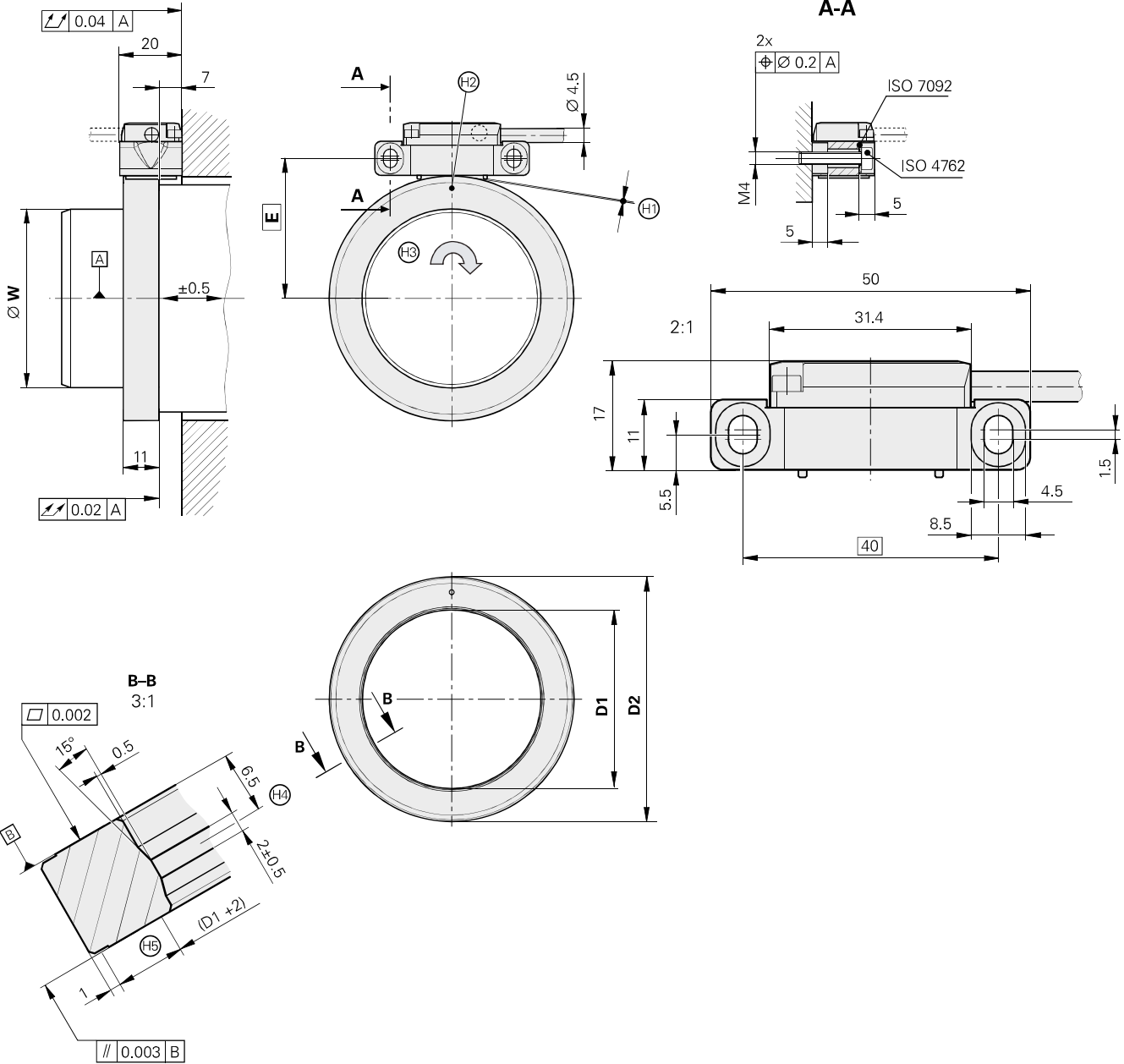

- ▣ = Bearing
- ⊕ = Mounting clearance 0.30 mm set with spacer foil
- ⊙ = Marker for reference mark, position tolerance with respect to reference mark $\pm 5^\circ$
- ⊕ = Direction of shaft rotation for output signals according to interface description
- ⊕ = Centering collar
- ⊕ = Clamping area (applies to both sides)

D1	W	D2	E
Ø 40 +0.010/+0.002	Ø 40 0/-0.006	Ø 58.06	34.7
Ø 55 +0.010/+0.002	Ø 55 0/-0.006	Ø 77.41	44.4
Ø 60 +0.010/+0.002	Ø 60 0/-0.006	Ø 90.72	51.1
Ø 100 +0.010/+0.002	Ø 100 0/-0.006	Ø 120.96	66.2

Scanning head	AK ERM 2980
Interface	$\sim 1 V_{PP}$
Cutoff frequency -3 dB	≥ 300 kHz
Signal period	≈ 1000 μ m
Line count*	See "Scale drum"
Electrical connection*	Cable 1 m, with or without coupling, tangential or axial cable outlet
Cable length	≤ 150 m (with HEIDENHAIN cable)
Voltage supply	5 V DC ± 0.5 V
Current requirement	≤ 150 mA (without load)
Vibration 55 to 2000 Hz Shock 6 ms	≤ 400 m/s ² (EN 60068-2-6) ≤ 1000 m/s ² (EN 60068-2-27)
Operating temperature	-10 °C to +100 °C
Protection EN 60529	IP67
Mass	≈ 0.15 kg (with cable)

Scale drum	ERM 2904			
Measuring standard	MAGNODUR graduation; signal period ≈ 1000 μ m			
Line count*	192	256	300	400
Position error per signal period ¹⁾	$\pm 68''$	$\pm 51''$	$\pm 44''$	$\pm 33''$
Accuracy of graduation	$\pm 68''$	$\pm 51''$	$\pm 44''$	$\pm 33''$
Reference mark	One			
Inside diameter*	40 mm	55 mm	60 mm	100 mm
Outside diameter	58.06 mm	77.41 mm	90.72 mm	120.96 mm
Mech. permissible speed	≤ 47000 rpm	≤ 35000 rpm	≤ 29000 rpm	≤ 16000 rpm
Moment of inertia of rotor	$0.07 \cdot 10^{-3}$ kgm ²	$0.22 \cdot 10^{-3}$ kgm ²	$0.45 \cdot 10^{-3}$ kgm ²	$0.92 \cdot 10^{-3}$ kgm ²
Permissible axial motion	± 0.5 mm			
Mass approx.	0.11 kg	0.19 kg	0.30 kg	0.30 kg

* Please select or indicate when ordering

¹⁾ The position error within one signal period and the accuracy of the graduation result together in the encoder-specific error; for additional error through mounting and the bearing of the measured shaft, see *Measuring accuracy*

Other line counts/dimensions upon request

Interfaces

Incremental signals $\sim 1 V_{PP}$

HEIDENHAIN encoders with $\sim 1 V_{PP}$ interface provide voltage signals that can be highly interpolated.

The sinusoidal **incremental signals** A and B are phase-shifted by 90° elec. and have amplitudes of typically $1 V_{PP}$. The illustrated sequence of output signals—with B lagging A—applies for the direction of motion shown in the dimension drawing.

The **reference mark signal** R has a usable component G of approx. $0.5 V$. Next to the reference mark, the output signal can be reduced by up to $1.7 V$ to a quiescent value H. This must not cause the subsequent electronics to overdrive. In the lowered signal level, too, signal peaks can appear with the amplitude G.

The data on **signal amplitude** apply when the supply voltage given in the specifications is connected to the encoder. They refer to a differential measurement at the 120Ω terminating resistor between the associated outputs. The signal amplitude decreases with increasing frequency. The **cutoff frequency** indicates the scanning frequency up to which a certain percentage of the original signal amplitude is maintained:

- $-3 \text{ dB} \triangleq 70\%$ of the signal amplitude
- $-6 \text{ dB} \triangleq 50\%$ of the signal amplitude

The data in the signal description apply to motions at up to 20% of the -3 dB -cutoff frequency.

Interpolation/resolution/measuring step

The output signals of the $1 V_{PP}$ interface are usually interpolated in the subsequent electronics in order to attain sufficiently high resolutions. For **velocity control**, interpolation factors are commonly over 1000 in order to receive usable information even at low rotational or linear velocities.

Measuring steps for **position measurement** are recommended in the specifications. For special applications, other resolutions are also possible.

Short-circuit stability

A temporary short circuit of one signal output to $0 V$ or U_P (except encoders with $U_{Pmin} = 3.6 V$) does not cause encoder failure, but it is not a permissible operating condition.

Short circuit at	20 °C	125 °C
One output	< 3 min	< 1 min
All outputs	< 20 s	< 5 s

Interface	Sinusoidal voltage signals $\sim 1 V_{PP}$
Incremental signals	Two nearly sinusoidal signals A and B Signal amplitude M: 0.6 to $1.2 V_{PP}$; typically $1 V_{PP}$ Asymmetry $ P - N /2M$: ≤ 0.065 Amplitude ratio M_A/M_B : 0.8 to 1.25 Phase angle $ \varphi_1 + \varphi_2 /2$: $90^\circ \pm 10^\circ$ elec.
Reference mark signal	One or several signal peaks R Usable component G: $\geq 0.2 V$ Quiescent value H: $\leq 1.7 V$ Switching threshold E, F: $0.04 V$ to $0.68 V$ Zero crossovers K, L: $180^\circ \pm 90^\circ$ elec.
Connecting cables	Shielded HEIDENHAIN cable e.g. PUR $[4(2 \times 0.14 \text{ mm}^2) + (4 \times 0.5 \text{ mm}^2)]$ Cable length: Max. 150 m at 90 pF/m distributed capacitance Propagation time: 6 ns/m

These values can be used for dimensioning of the subsequent electronics. Any limited tolerances in the encoders are listed in the specifications. For encoders without integral bearing, reduced tolerances are recommended for initial operation (see the mounting instructions).

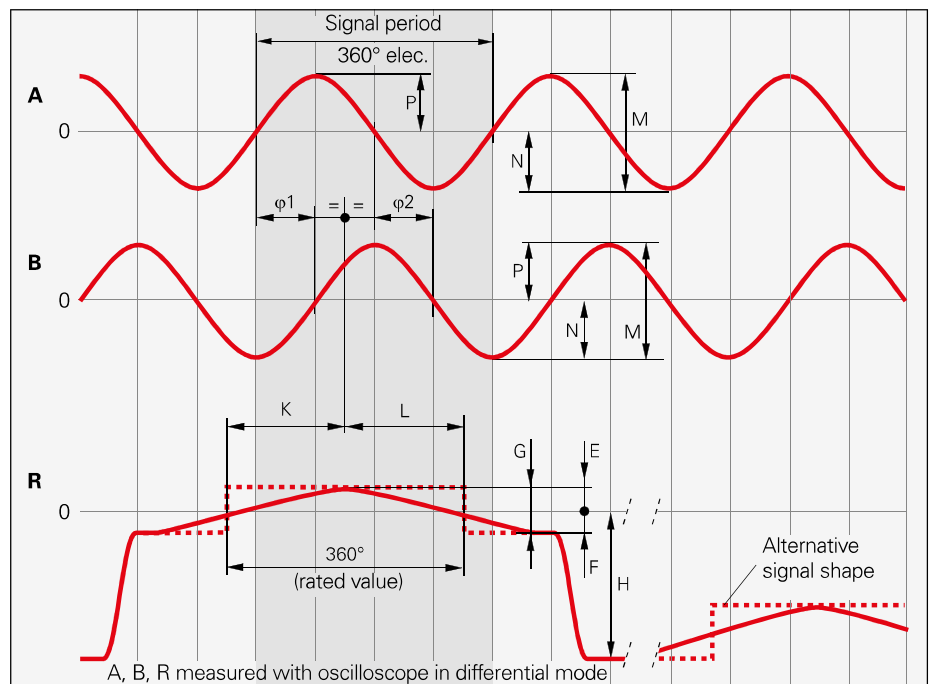

Cut-off frequency

Typical signal amplitude curve with respect to the scanning frequency (depends on encoder)

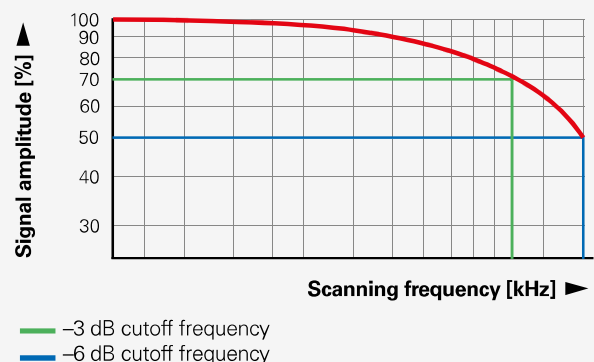

Input circuitry of subsequent electronics

Dimensioning

Operational amplifier MC 34074

$Z_0 = 120 \Omega$

$R_1 = 10 \text{ k}\Omega$ and $C_1 = 100 \text{ pF}$

$R_2 = 34.8 \text{ k}\Omega$ and $C_2 = 10 \text{ pF}$

$U_B = \pm 15 \text{ V}$

U_1 approx. U_0

-3 dB cutoff frequency of circuitry

$\approx 450 \text{ kHz}$

$\approx 50 \text{ kHz}$ with $C_1 = 1000 \text{ pF}$
and $C_2 = 82 \text{ pF}$

The circuit variant for 50 kHz does reduce the bandwidth of the circuit, but in doing so it improves its noise immunity.

Encoders with **higher signal frequencies** (e.g. LIP 281) require special input circuitry (see the *Exposed Linear Encoders* brochure).

Circuit output signals

$U_a = 3.48 V_{PP}$ typically

Gain 3.48

Monitoring of the incremental signals

The following sensitivity levels are recommended for monitoring the signal amplitude M:

Lower threshold: $0.30 V_{PP}$

Upper threshold: $1.35 V_{PP}$

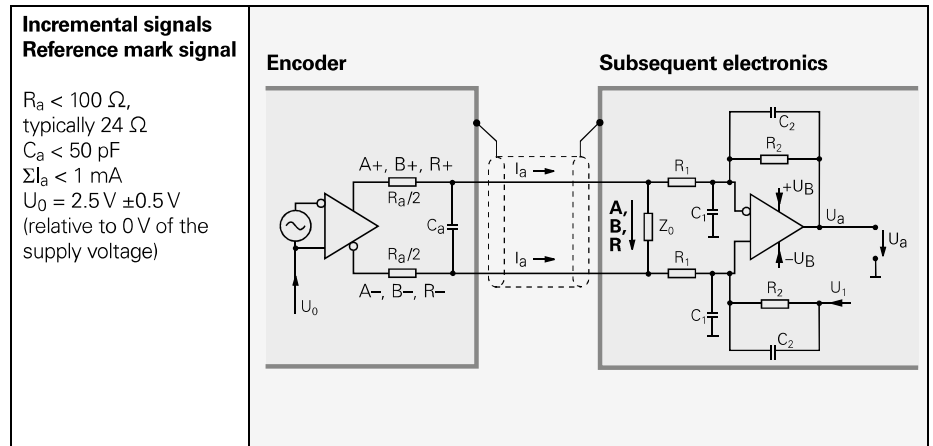

Incremental signals Reference mark signal

$R_a < 100 \Omega$,
typically 24Ω
 $C_a < 50 \text{ pF}$
 $\Sigma I_a < 1 \text{ mA}$
 $U_0 = 2.5 \text{ V} \pm 0.5 \text{ V}$
(relative to 0 V of the
supply voltage)

Pin layout

12-pin coupling, M23				12-pin connector, M23									
15-pin D-sub connector For HEIDENHAIN controls and IK 220				15-pin D-sub connector For encoders or IK 215									
	Voltage supply			Incremental signals						Other signals			
	12	2	10	11	5	6	8	1	3	4	9	7	/
	1	9	2	11	3	4	6	7	10	12	5/8/13/15	14	/
	4	12	2	10	1	9	3	11	14	7	5/6/8/15	13	/
	U_P	Sensor U_P	0V	Sensor 0V	A+	A-	B+	B-	R+	R-	Vacant	Vacant	Vacant
	Brown/ Green	Blue	White/ Green	White	Brown	Green	Gray	Pink	Red	Black	/	Violet	Yellow

Cable shield connected to housing; U_P = power supply voltage

Sensor: The sensor line is connected in the encoder with the corresponding power line.

Vacant pins or wires must not be used!

Incremental signals

HEIDENHAIN encoders with  interface incorporate electronics that digitize sinusoidal scanning signals with or without interpolation.

The **incremental signals** are transmitted as the square-wave pulse trains U_{a1} and U_{a2} , phase-shifted by 90° elec. The **reference mark signal** consists of one or more reference pulses U_{a0} , which are gated with the incremental signals. In addition, the integrated electronics produce their **inverted signals** $\overline{U_{a1}}$, $\overline{U_{a2}}$ and $\overline{U_{a0}}$ for noise-proof transmission. The illustrated sequence of output signals—with U_{a2} lagging U_{a1} —applies to the direction of motion shown in the dimension drawing.

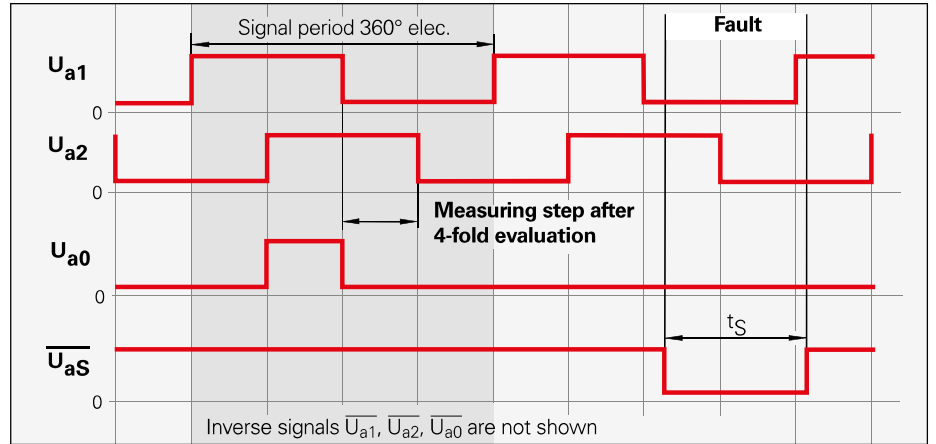









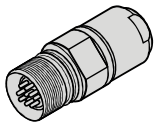
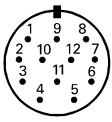

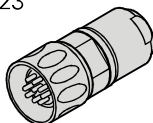
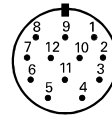
The **fault detection signal** $\overline{U_{aS}}$ indicates fault conditions such as an interruption in the supply lines, failure of the light source, etc.

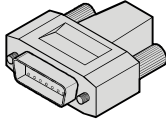
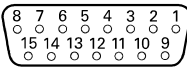
Comprehensive descriptions of all available interfaces as well as general electrical information are included in the *Interfaces of HEIDENHAIN Encoders* brochure.

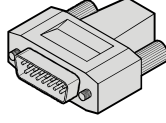
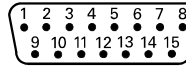
The distance between two successive edges of the incremental signals U_{a1} and U_{a2} through 1-fold, 2-fold or 4-fold evaluation is one **measuring step**.

Pin layout

12-pin coupling, M23   					12-pin connector, M23   								
15-pin D-sub connector For HEIDENHAIN controls and IK 220   					15-pin D-sub connector For encoder or PWM 20   								
	Voltage supply				Incremental signals						Other signals		
	12	2	10	11	5	6	8	1	3	4	7	/	9 ³⁾
	1	9	2	11	3	4	6	7	10	12	14	8/13/15	5
	4	12	2	10	1	9	3	11	14	7	13	5/6/8	15 ³⁾
	U_P	Sensor ¹⁾ U_P	0V	Sensor ¹⁾ 0V	U_{a1}	$\overline{U_{a1}}$	U_{a2}	$\overline{U_{a2}}$	U_{a0}	$\overline{U_{a0}}$	$\overline{U_{aS}}$ ²⁾	Vacant	Vacant
	Brown/ Green	Blue	White/ Green	White	Brown	Green	Gray	Pink	Red	Black	Violet	/	Yellow

Cable shield connected to housing; U_P = power supply voltage

Sensor: The sensor line is connected in the encoder with the corresponding power line.

Vacant pins or wires must not be used!

¹⁾ LIDA 2xx: Vacant

²⁾ ERO 14xx: Vacant

³⁾ **Exposed linear encoders:** Switchover TTL/11 μA_{PP} for PWT, otherwise vacant

Interfaces

Position values

The EnDat interface is a digital, **bidirectional** interface for encoders. It is capable both of transmitting **position values** as well as transmitting or updating information stored in the encoder, or saving new information. Thanks to the **serial transmission method**, only **four signal lines** are required. The DATA data is transmitted in **synchronism** with the CLOCK signal from the subsequent electronics. The type of transmission (position values, parameters, diagnostics, etc.) is selected through mode commands that the subsequent electronics send to the encoder. Some functions are available only with EnDat 2.2 mode commands.

Comprehensive descriptions of all available interfaces as well as general electrical information are included in the *Interfaces for HEIDENHAIN Encoders* catalog.

Ordering designation	Command set	Incremental signals
EnDat01	EnDat 2.1 or EnDat 2.2	With
EnDat21		Without
EnDat02	EnDat 2.2	With
EnDat22	EnDat 2.2	Without

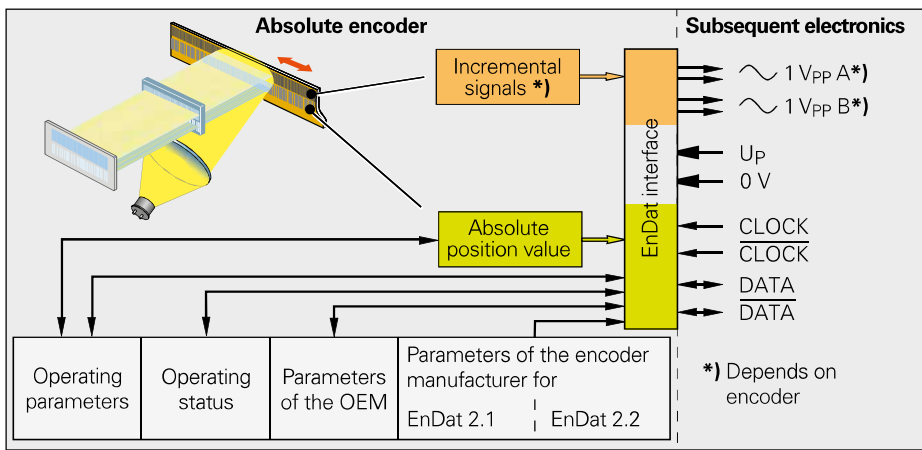

Versions of the EnDat interface

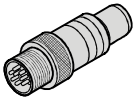
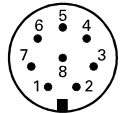

Pin layout

8-pin coupling, M12







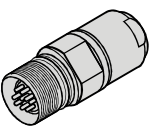
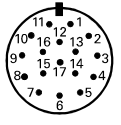

	Voltage supply				Absolute position values			
	8	2	5	1	3	4	7	6
	UP	Sensor UP	0V	Sensor 0V	DATA	DATA	CLOCK	CLOCK
	Brown/Green	Blue	White/Green	White	Gray	Pink	Violet	Yellow

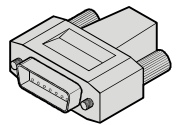
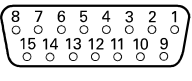
17-pin coupling, M23

15-pin D-sub connector
For HEIDENHAIN controls and IK 220

	Power supply				Incremental signals ¹⁾					Absolute position values			
	7	1	10	4	11	15	16	12	13	14	17	8	9
	1	9	2	11	13	3	4	6	7	5	8	14	15
	UP	Sensor UP	0V	Sensor 0V	Internal shield	A+	A-	B+	B-	DATA	DATA	CLOCK	CLOCK
	Brown/Green	Blue	White/Green	White	/	Green/Black	Yellow/Black	Blue/Black	Red/Black	Gray	Pink	Violet	Yellow

Cable shield connected to housing; **UP** = power supply voltage
Sensor: The sensor line is connected in the encoder with the corresponding power line.
 Vacant pins or wires must not be used!
¹⁾ Only with ordering designations EnDat01 and EnDat02

Cables and connecting elements

General information

Connector (insulated): Connecting element with coupling ring; available with male or female contacts (see symbols).

Symbols

M12

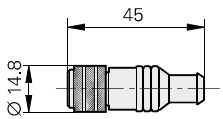

Right-angle connector M12

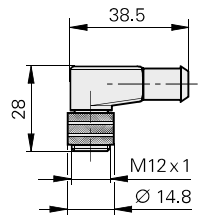

M23

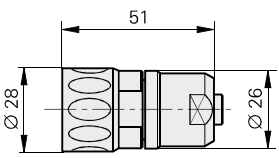

Coupling (insulated): Connecting element with external thread; available with male or female contacts (see symbols).

On the adapter cable

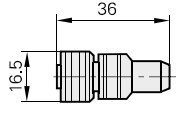

Symbols

M12

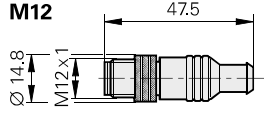

M23

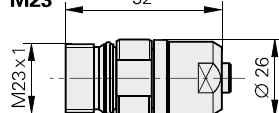

Mounted coupling with central fastening

Cutout for mounting

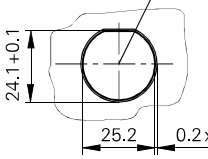

M23

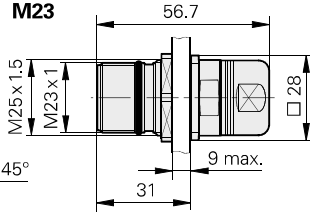

Mounted coupling with flange

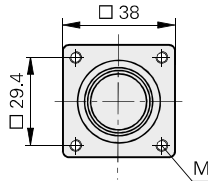

M23

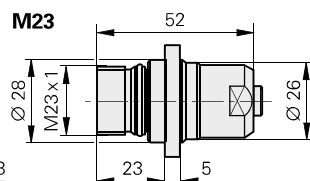

D-sub connector for HEIDENHAIN controls, counters and IK absolute value cards.

Symbols

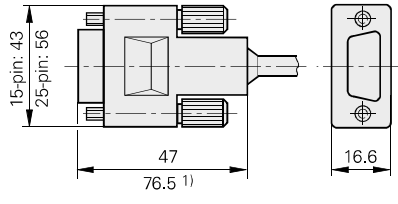

¹⁾ With integrated interface electronics

Flange socket with external thread; permanently mounted on a housing, available with male or female contacts.

Symbols

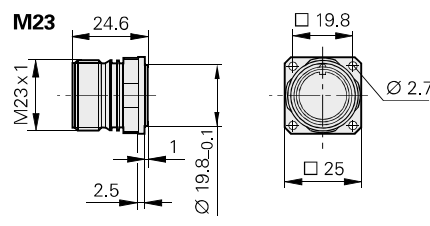

The pins on connectors are **numbered** in the direction opposite to those on couplings or flange sockets, regardless of whether the connecting elements have

male contacts or



female contacts.



Accessory for flange sockets and M23 mounted couplings

Threaded metal dust cap
ID 219926-01

Accessory for M12 connecting element
Insulation spacer
ID 596495-01

When engaged, the connections provide **protection** to IP67 (D-sub connector: IP50; EN 60529). When not engaged, there is no protection.

Connecting cables

8-pin
M12

17-pin
M23

		for EnDat without incremental signals	for $\sim 1V_{PP}$ \square TTL
PUR connecting cables	8-pin: $[(4 \times 0.14 \text{ mm}^2) + (4 \times 0.34 \text{ mm}^2)]$; $A_P = 0.34 \text{ mm}^2$ 12-pin: $[4(2 \times 0.14 \text{ mm}^2) + (4 \times 0.5 \text{ mm}^2)]$; $A_P = 0.5 \text{ mm}^2$		$\varnothing 6 \text{ mm}$ $\varnothing 8 \text{ mm}$
Complete with connector (female) and coupling (male)		368330-xx	298401-xx
Complete with connectors (female and male)		–	298399-xx
Complete with connector (female) and 15-pin D-sub connector (female)		533627-xx	310199-xx
Complete with connector (female) and 15-pin coupling (male)		524599-xx	310196-xx
With one connector (female)		634265-xx	309777-xx
Cable only		816329-xx	816317-xx
Mating element on connecting cable to connector on encoder cable	Connector (female) for cable $\varnothing 8 \text{ mm}$ 	–	291697-05
Connector on cable for connection to subsequent electronics	Connector (male) for cable $\varnothing 4.5 \text{ mm}$ $\varnothing 6 \text{ mm}$ $\varnothing 8 \text{ mm}$ 	–	291697-06 291697-07 291697-08
Coupling on connecting cable	Coupling (male) for cable $\varnothing 4.5 \text{ mm}$ $\varnothing 6 \text{ mm}$ $\varnothing 8 \text{ mm}$ 	–	291698-14 291698-03 291698-04
Flange socket for mounting on subsequent electronics	Flange socket (female) 	–	315892-08
Mounted couplings	With flange (female) $\varnothing 6 \text{ mm}$ $\varnothing 8 \text{ mm}$ 	–	291698-17 291698-07
	With flange (male) $\varnothing 6 \text{ mm}$ $\varnothing 8 \text{ mm}$ 	–	291698-08 291698-31
	With central fastening (male) $\varnothing 6 \text{ to } 10 \text{ mm}$ 	–	741045-01
Adapter $\sim 1V_{PP}/11 \mu A_{PP}$ For converting the $1V_{PP}$ signals to $11 \mu A_{PP}$; M23 connector (female, 12-pin) and M23 connector (male), 9-pin		–	364914-01

A_P : Cross section of power supply lines

Diagnostic and testing equipment

HEIDENHAIN encoders are provided with all information necessary for commissioning, monitoring and diagnostics. The type of available information depends on whether the encoder is incremental or absolute and which interface is used.

Incremental encoders mainly have 1 V_{PP} TTL or HTL interfaces. TTL and HTL encoders monitor their signal amplitudes internally and generate a simple fault detection signal. With 1 V_{PP} signals, the analysis of output signals is possible only in external test devices or through computation in the subsequent electronics (**analog diagnostics interface**).

Absolute encoders operate with serial data transfer. Depending on the interface, additional 1 V_{PP} incremental signals can be output. The signals are monitored comprehensively within the encoder. The monitoring result (especially with valuation numbers) can be transferred along with the position value through the serial interface to the subsequent electronics (**digital diagnostics interface**). The following information is available:

- Error message: Position value not reliable
- Warning: An internal functional limit of the encoder has been reached
- Valuation numbers:
 - Detailed information on the encoder's functional reserve
 - Identical scaling for all HEIDENHAIN encoders
 - Cyclic output is possible

This enables the subsequent electronics to evaluate the current status of the encoder with little effort even in closed-loop mode.

HEIDENHAIN offers the appropriate PWM inspection devices and PWT test devices for encoder analysis. There are two types of diagnostics, depending on how the devices are integrated:

- Encoder diagnostics: The encoder is connected directly to the test or inspection device. This makes a comprehensive analysis of encoder functions possible.
- Diagnostics in the control loop: The PWM phase meter is looped into the closed control loop (e.g. through a suitable testing adapter). This makes a real-time diagnosis of the machine or system possible during operation. The functions depend on the interface.

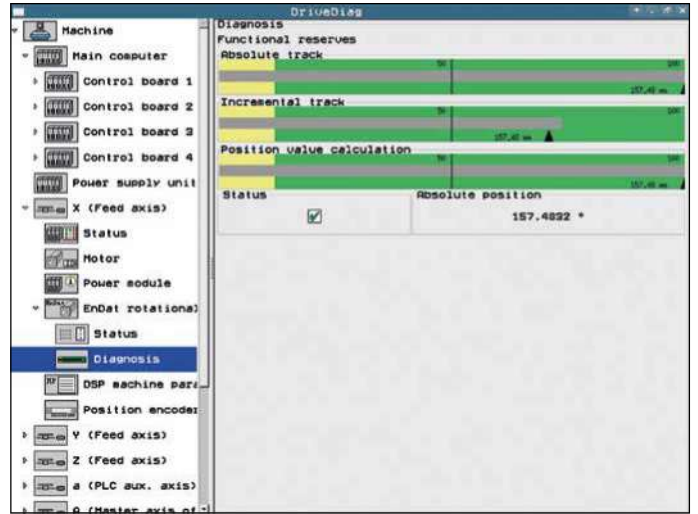

Diagnostics in the control loop on HEIDENHAIN controls with display of the valuation number or the analog encoder signals

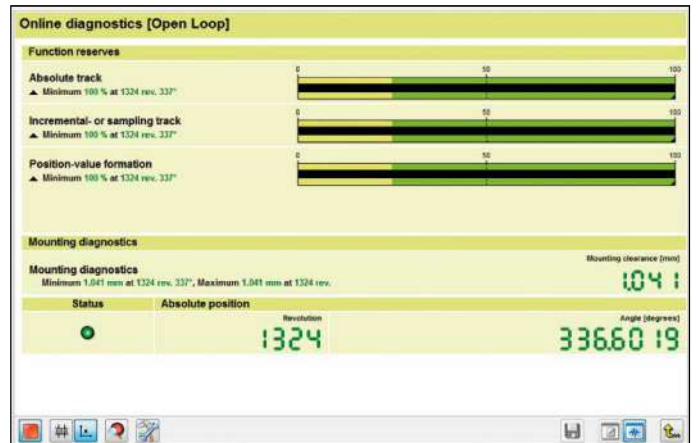

Diagnostics using PWM 20 and ATS software



Commissioning using PWM 20 and ATS software

PWM 20

The PWM 20 phase angle measuring unit serves together with the provided ATS adjusting and testing software for diagnosis and adjustment of HEIDENHAIN encoders.



For more information, refer to the Product Information document *PWM 20/ATS Software*.

	PWM 20
Encoder input	<ul style="list-style-type: none"> • EnDat 2.1 or EnDat 2.2 (absolute value with/without incremental signals) • DRIVE-CLiQ • Fanuc Serial Interface • Mitsubishi high speed interface • Yaskawa Serial Interface • Panasonic serial interface • SSI • 1 V_{PP}/TTL/11 μA_{PP} • HTL (via signal adapter)
Interface	USB 2.0
Voltage supply	100 V to 240 V AC or 24 V DC
Dimensions	258 mm x 154 mm x 55 mm

	ATS
Languages	Choice between English and German
Functions	<ul style="list-style-type: none"> • Position display • Connection dialog • Diagnostics • Mounting wizard for EBI/ECI/EQI, LIP 200, LIC 4000 and others • Additional functions (if supported by the encoder) • Memory contents
System requirements and recommendations	PC (dual-core processor, > 2 GHz) RAM > 2 GB Windows operating systems XP, Vista, 7 (32-bit/64-bit), 8 200 MB free space on hard disk

DRIVE-CLiQ is a registered trademark of Siemens Aktiengesellschaft

The **PWM 9** is a universal measuring device for checking and adjusting HEIDENHAIN incremental encoders. Expansion modules are available for checking the various types of encoder signals. The values can be read on an LCD monitor. Soft keys provide ease of operation.



	PWM 9
Inputs	Expansion modules (interface boards) for 11 μA _{PP} ; 1 V _{PP} ; TTL; HTL; EnDat*/SSI*/commutation signals *No display of position values or parameters
Functions	<ul style="list-style-type: none"> • Measures signal amplitudes, current consumption, operating voltage, scanning frequency • Graphically displays incremental signals (amplitudes, phase angle and on-off ratio) and the reference-mark signal (width and position) • Displays symbols for the reference mark, fault-detection signal, counting direction • Universal counter, interpolation selectable from single to 1024-fold • Adjustment support for exposed linear encoders
Outputs	<ul style="list-style-type: none"> • Inputs are connected through to the subsequent electronics • BNC sockets for connection to an oscilloscope
Voltage supply	10 V to 30 V DC, max. 15 W
Dimensions	150 mm x 205 mm x 96 mm

Interface electronics

Interface electronics from HEIDENHAIN adapt the encoder signals to the interface of the subsequent electronics. They are used when the subsequent electronics cannot directly process the output signals from HEIDENHAIN encoders, or if additional interpolation of the signals is necessary.

Input signals of the interface electronics

Interface electronics from HEIDENHAIN can be connected to encoders with sinusoidal signals of $1 V_{PP}$ (voltage signals) or $11 \mu A_{PP}$ (current signals). Encoders with the serial interfaces EnDat or SSI can also be connected to various interface electronics.

Output signals of the interface electronics

Interface electronics with the following interfaces to the subsequent electronics are available:

- TTL square-wave pulse trains
- EnDat 2.2
- DRIVE-CLiQ
- Fanuc Serial Interface
- Mitsubishi high speed interface
- Yaskawa Serial Interface
- Profibus

Interpolation of the sinusoidal input signals

In addition to being converted, the sinusoidal encoder signals are also interpolated in the interface electronics. This permits finer measuring steps and, as a result, higher control quality and better positioning behavior.

Formation of a position value

Some interface electronics have an integrated counting function. Starting from the last reference point set, an absolute position value is formed when the reference mark is traversed, and is transferred to the subsequent electronics.

Box design



Plug design



Version for integration



Top-hat rail design

