



HEIDENHAIN

araxe

72, rue Yves le Coz
78000 VERSAILLES

tél : 01 30 21 48 49

fax : 01 39 51 16 33

<http://www.araxe.com>

contact@araxe.com

HEIDENHAIN



**Functional
Safety**

Product Information

ECI 1319

EQI 1331

EBI 1335

Absolute Rotary Encoders
without Integral Bearing

Suited for safety-related
applications up to SIL 3
when coupled with
additional measures

09/2018

Specifications	ECI 1319 – Singleturn	EQI 1331 – Multiturn	EBI 1335 – Multiturn
ID number	810661-02 (shaft 44C) 810661-03 (shaft 44A) 810661-06 (shaft 44C) ¹⁾	810662-01 (shaft 44A) 810662-03 (shaft 44C) 810662-06 (shaft 44C) ¹⁾	1230275-01 (shaft 44C) 1230275-02 (shaft 44A)
Functional safety for applications up to	As single-encoder system for monitoring and closed-loop functions: <ul style="list-style-type: none"> • SIL 2 as per EN 61508 (further basis for testing: EN 61800-5-2) • Category 3, PL d as per EN ISO 13849-1:2015 With additional measures as per document 1000344 for safety-related applications up to SIL 3 or category 4, PL e Safe in the singleturn range		
PFH	<i>SIL 2:</i> $\leq 15 \cdot 10^{-9}$ (Probability of dangerous Failure per Hour) <i>SIL 3:</i> $\leq 2 \cdot 10^{-9}$		
Safe position ²⁾	<i>Encoder:</i> $\pm 0.88^\circ$ (safety-related measuring step SM = 0.35°) <i>Mechanical coupling:</i> 0° (fault exclusion for loosening of shaft and stator coupling, designed for accelerations of $\leq 400 \text{ m/s}^2$ on the stator and $\leq 600 \text{ m/s}^2$ on the rotor)		
Interface	EnDat 2.2		
Ordering designation	EnDat22		
Position values per revolution	524 288 (19 bits)		
Revolutions	–	4096 (12 bits)	65563 (16 bits)
Calculation time t_{cal} Clock frequency	$\leq 5 \mu\text{s}$ $\leq 16 \text{ MHz}$		
System accuracy	$\pm 65''$		
Electrical connection	16-pin PCB connector (with connection for external temperature sensor)		
Cable length	$\leq 100 \text{ m}$ (see EnDat description in the brochure titled <i>Interfaces of HEIDENHAIN Encoders</i>)		
Supply voltage	DC 3.6 V to 14 V		Rotary encoder U_p : DC 3.6 V to 14 V Backup battery U_{Bat} : DC 3.6 V to 5.25 V
Power consumption ³⁾ (maximum)	At 3.6 V: $\leq 650 \text{ mW}$ At 14 V: $\leq 700 \text{ mW}$	At 3.6 V: $\leq 750 \text{ mW}$ At 14 V: $\leq 850 \text{ mW}$	At 3.6 V: $\leq 650 \text{ mW}$ At 14 V: $\leq 700 \text{ mW}$
Current consumption (typical)	At 5 V: 95 mA (without load)	At 5 V: 115 mA (without load)	Normal operation at 5 V: 95 mA (without load) Buffer mode: 160 μA (rotating shaft) ⁴⁾ 16 μA (at standstill)

¹⁾ In collective package

²⁾ Further tolerances may occur in subsequent electronics after position value comparison (contact manufacturer of subsequent electronics)

³⁾ See *General electrical information* in the *Interfaces of HEIDENHAIN Encoders* brochure or at www.heidenhain.de

⁴⁾ At $T = 25 \text{ }^\circ\text{C}$; $U_{\text{Bat}} = 3.6 \text{ V}$

Specifications	ECI 1319 – Singleturn	EQI 1331 – Multiturn	EBI 1335 – Multiturn
Shaft*	Blind hollow shaft for axial clamping Ø 12.7 mm (44C) or Ø 12 mm (44A)		
Shaft speed	≤ 15000 rpm	≤ 12000 rpm	
Moment of inertia of rotor	$2.45 \cdot 10^{-6} \text{ kgm}^2$	$2.6 \cdot 10^{-6} \text{ kgm}^2$	$2.45 \cdot 10^{-6} \text{ kgm}^2$
Angular acceleration of rotor	≤ $1 \cdot 10^5 \text{ rad/s}^2$		
Axial motion of measured shaft	≤ ±0.5 mm		
Vibration 55 Hz to 2000 Hz ¹⁾ Shock 6 ms	<i>Stator:</i> ≤ 400 m/s ² ; <i>rotor:</i> ≤ 600 m/s ² (EN 60068-2-6) ≤ 2000 m/s ² (EN 60068-2-27)		
Operating temperature	−40 °C to 115 °C		
Trigger threshold of error message for excessive temperature	130 °C (measuring accuracy of internal temperature sensor: ±1 K)		
Relative humidity	≤ 93 % (40 °C/21 d as per EN 60068-2-78); without condensation		
Protection EN 60529	IP20		
Mass	≈ 0.13 kg		

* Please select when ordering

¹⁾ 10 Hz to 55 Hz constant over distance 4.9 mm peak to peak

Mounting

The blind hollow shaft of the rotary encoder is slid onto the measured shaft and fastened with a central screw. The stator is mounted by a centering diameter with three mounting screws. In each case, use screws with materially bonding anti-rotation lock (see *Mounting accessories*).

The following material properties and conditions must be complied with when customers plan and execute installation.

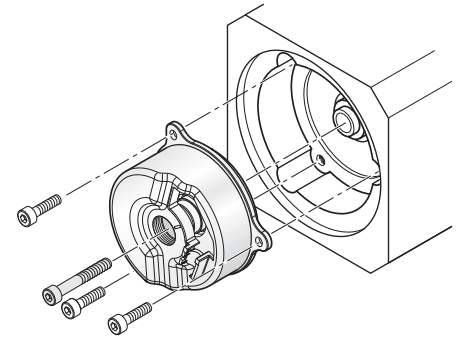

	Mating stator	Mating shaft
Material	Aluminum	Steel
Tensile strength R_m	$\geq 220 \text{ N/mm}^2$	$\geq 600 \text{ N/mm}^2$
Yield strength $R_{p,0.2}$ or yield point R_e	–	$\geq 400 \text{ N/mm}^2$
Shear strength τ_m	130 N/mm^2	$\geq 390 \text{ N/mm}^2$
Interface pressure P_G	$\geq 250 \text{ N/mm}^2$	$\geq 660 \text{ N/mm}^2$
Modulus of elasticity E (at 20 °C)	70 kN/mm^2 to 75 kN/mm^2	200 kN/mm^2 to 215 kN/mm^2
Coefficient of thermal expansion α_{therm} (at 20 °C)	$\leq 25 \cdot 10^{-6} \text{ K}^{-1}$	$10 \cdot 10^{-6} \text{ K}^{-1}$ to $17 \cdot 10^{-6} \text{ K}^{-1}$
Surface roughness R_z	$\leq 16 \text{ }\mu\text{m}$	
Friction values	Mounting surfaces must be clean and free of grease. Use screws and washers in the condition as delivered.	
Tightening process	Use a signaling torque tool according to DIN EN ISO 6789; accuracy $\pm 6 \%$	
Mounting temperature	15 °C to 35 °C	

Mounting accessories

Screws

Screws (central screw, mounting screws) are not included in delivery. They can be ordered separately.

ECN 1319 EQN 1331 EBI 1335	Screws ¹⁾		Lot size
Central screw for fastening the shaft	DIN 6912- M5×30-08.8-MKL	ID 202264-76	10 or 100 pieces
Mounting screw for flange	ISO 4762- M4×10-8.8-MKL	ID 202264-85	30 or 300 pieces

¹⁾ With coating for materially bonding anti-rotation lock

Please note the information on screws from HEIDENHAIN in the brochure titled *Encoders for Servo Drives*, chapter *General mechanical information* under *Rotary encoders with functional safety*.

Mounting aid

To avoid damage to the cable, use the mounting aid to connect and disconnect the cable assembly. The pulling force must be applied only to the connector of the cable assembly, and not to the wires.

ID 1075573-01

For further mounting information and mounting aids, refer to the mounting instructions and the *Encoders for Servo Drives* brochure. The installation can be inspected with the PWM 21 and the ATS software (see document 1082415).



Electrical connection





Cables

EPG encoder cable inside the motor \varnothing 3.7 mm (with shield crimping \varnothing 6.1 mm); 1 x (4 x 0.06 mm ²) + 4 x 0.06 mm ² and TPE wires 2 x 0.16 mm ² for temperature sensor		
With PCB connector, 16-pin and M23 SpeedTEC angle flange socket, male, 9-pin		ID 1120948-xx

¹⁾ **Note for safety-related applications:**

- Provide bit error rate as per specification 533095!
- CE compliance of the complete system must be documented!

SpeedTEC is a registered trademark of TE Connectivity Industrial GmbH

PUR adapter and connecting cable \varnothing 6 m; (4 x 0.14 mm ²) + (4 x 0.34 mm ²); $A_P = 0.34$ mm ²		M12 connector, 8-pin	M23 connector, 9-pin
Connecting cable with M23 connector, female, 9-pin and M12 coupling, male, 8-pin		-	ID 745796-xx
Adapter cable with M12 connector, female, 8-pin and D-sub connector, female, 15-pin		ID 533627-xx	
Adapter cable with M12 connector, female, 8-pin and D-sub connector, male, 15-pin		ID 524599-xx	
Connecting cable with M12 connector, female, 8-pin and without connecting element		ID 634265-xx ¹⁾	

A_P : Cross section of power lines







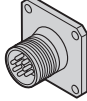

¹⁾ Connecting element must be suitable for the maximum clock frequency used

Note for safety-related applications:

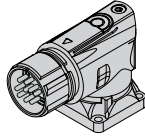
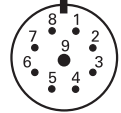
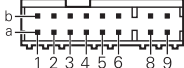
- Provide bit error rate as per specification 533095!
- CE compliance of the complete system must be documented!

Electrical connection

Pin layout of ECI, EQI

Coupling, 8-pin or M12 flange socket, 8-pin   				M23 SpeedTEC angle flange socket, 9-pin   						
PCB connector, 16-pin   16										
	Voltage supply				Serial data transfer				Other signals	
 M12	8	2	5	1	3	4	7	6	/	/
 M23	3	7	4	8	5	6	1	2	/	/
 16	1b	6a	4b	3a	6b	1a	2b	5a	8a	8b
	U_P	Sensor U_P	0V	Sensor 0V	DATA	$\overline{\text{DATA}}$	CLOCK	$\overline{\text{CLOCK}}$	$T+^{1)}$	$T-^{1)}$
	Brown/ Green	Blue	White/ Green	White	Gray	Pink	Violet	Yellow	Brown	Green

¹⁾ Connections for external temperature sensor; evaluation optimized for KTY 84-130 (see *Temperature measurement in motors* in the *Encoders for Servo Drives* brochure)

Cable shield connected to housing; U_P = Power supply voltage







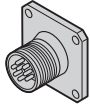

Sensor: The sense line is connected in the encoder with the corresponding power line.

Vacant pins or wires must not be used!

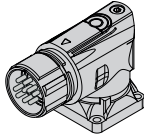
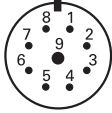
Note for safety-related applications: Only completely assembled HEIDENHAIN cables are qualified. Do not modify cables or exchange their connectors without first consulting with HEIDENHAIN Traunreut.

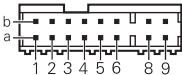
SpeedTEC is a registered trademark of TE Connectivity Industrial GmbH

Pin layout of EBI

Coupling, 8-pin or M12 flange socket, 8-pin   		M23 SpeedTEC angle flange socket, 9-pin   								
PCB connector, 16-pin  										
	Voltage supply				Serial data transfer				Other signals	
 M12	8	2	5	1	3	4	7	6	/	/
 M23	3	7	4	8	5	6	1	2	/	/
 16	1b	6a	4b	3a	6b	1a	2b	5a	8a	8b
	U_P	U_{BAT}	$0V^{2)}$	$0V_{BAT}^{2)}$	DATA	\overline{DATA}	CLOCK	\overline{CLOCK}	T^+ ¹⁾	T^- ¹⁾
	Brown/ Green	Blue	White/ Green	White	Gray	Pink	Violet	Yellow	Brown	Green

¹⁾ Connections for external temperature sensor; evaluation optimized for KTY 84-130 (see *Temperature measurement in motors* in the *Encoders for Servo Drives* brochure)

²⁾ Connected inside encoder

Cable shield connected to housing; U_P = Power supply voltage

Sensor: The sense line is connected in the encoder with the corresponding power line.

Vacant pins or wires must not be used!

Note for safety-related applications: Only completely assembled HEIDENHAIN cables are qualified. Do not modify cables or exchange their connectors without first consulting with HEIDENHAIN Traunreut.

SpeedTEC is a registered trademark of TE Connectivity Industrial GmbH

HEIDENHAIN

DR. JOHANNES HEIDENHAIN GmbH

Dr.-Johannes-Heidenhain-Straße 5

83301 Traunreut, Germany

☎ +49 8669 31-0

FAX +49 8669 32-5061

E-mail: info@heidenhain.de

This Product Information document supersedes all previous editions, which thereby become invalid. The basis for ordering from HEIDENHAIN is always the Product Information document edition valid when the order is made.



More information:

Comply with the requirements described in the following documents to ensure the correct operation of the encoder:

- *Encoders for Servo Drives* brochure: 208922-xx
- *Cables and Connectors* brochure: 1206103-xx
- *Interfaces* brochure: 1078628-xx
- Mounting instructions for ECI 1319, EQI 1331: 1000453-xx
- *Safety-Related Position Measuring Systems* Technical Information: 596632
- For implementation in a safe control or inverter, refer to *Specification*: 533095
- and *Supplementary Catalog of Measures* (SIL 3, PL e): 1000344